

INTRODUCTION TO THE BALLY ELECTRONIC SLOT

This manual describes the operation of BALLY'S ELECTRONIC SLOT MACHINE. You will find, in comparing this machine with the electromechanical version, that the same basic functions and timing relationships exist*. In fact, the only visible difference to the player is the addition of a 6 digit LED (Light Emitting Diode) display**. This display, in addition to providing the function of WIN METER, also performs several other useful functions. For example, a slot machine attendant, called to the machine by a player, will be able to determine by observing the code on the LED display, whether the machine has detected a problem in its operation. If there is a problem, the code will tell the attendant if it is a coin jam, empty hopper, or something more serious, requiring a technician. The code displayed will also help the technician localize the problem. The LED display also permits the reading of meters without entering the machine.

For the sake of discussion, when referring to examples of the LED display, this manual describes the digit positions within the display as columns 1 thru 6, from left to right.



Examples of what might be observed in the LED displays of the Series 1000 (small round windows) and the Series 2000 (larger rectangular windows). The operation of the test procedures are very similar in both series. When performing a test on the Series 1000 use the same codes displayed as used on the Series 2000, except in cases where variations are noted by the addition of the small round window LED displays.

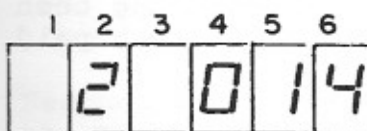

Bally has taken advantage of the advanced technology of integrated circuits (IC's) to incorporate into the machine reliability, flexibility, as well as bookkeeping, security, and maintenance features which would have been impractical, if not impossible, a few years ago. A microprocessor-based system was determined to be the most effective approach to achieve these desirable objectives. The MICROPROCESSOR (CPU) is an IC that performs the functions of the central processing unit of a computer. Thus, it controls the interpretation and execution of instructions. These electrically coded instructions, called a PROGRAM, are stored in other IC's, called MEMORY CHIPS. The CPU receives information in the form of INPUTS, which tell the CPU the status of SWITCHES, REELS, ETC. This enables the CPU to determine which OUTPUTS (coils, lamps, motors) should be on or off for the particular MODE of operation that the machine is in. (ACCEPTING COINS, READING REELS, DISPENSING COINS, DISPLAYING METERS, SELF-TESTING, ETC.)

The CPU, MEMORY CHIPS, and other CONTROL LOGIC are located on a MICROPROCESSOR UNIT (MPU) BOARD.

* See Reel Spin Time Variations on Page 24.

** An exception to this is a model which contains a Replay Register (Credit Meter) or Progressive Jackpot Meter.

WHAT TO EXPECT WHEN POWER IS APPLIED

When power is applied, a brief self-test of vital functions of the MPU board will occur. During this self-test coins are locked out. After completion of this self-test, the slot machine will return to some point in its normal operation. This point is determined by what the machine was doing when power was turned off. THE CENTER TWO DECIMAL POINTS INDICATE A RESET (POWER OFF, STATIC DISCHARGE, ETC.) OCCURRED SINCE THE LAST HANDLE PULL.

The 6-DIGIT LED DISPLAY may appear as any of the 3 following examples when power is turned on. If the display exhibits a severe flicker or takes a form other than those mentioned below, see BUILT-IN TEST FUNCTIONS paragraph on following page.

1. Machine was at some point in its normal operating sequence when power was removed.

Example:

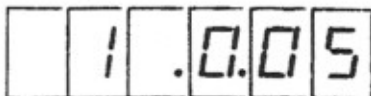
A 6-digit LED display showing the number 1.005. The digits are arranged in six boxes: the first box is empty, the second shows '1', the third shows a decimal point, the fourth shows '0', the fifth shows '0', and the sixth shows '5'.

The number in the second column, in this example 1, indicates one coin was put into machine for previous game and the 005 in the fourth, fifth and sixth columns indicates number of coins paid out. (In this case 5 coins).

Example:

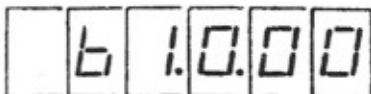
A 6-digit LED display showing the number 61.000. The digits are arranged in six boxes: the first shows '6', the second shows '1', the third shows a decimal point, the fourth shows '0', the fifth shows '0', and the sixth shows '0'.

In this example 6 coins had been played; 1000 coins had been paid out.

2. The processor had detected a game malfunction prior to power being removed.

NOTE: Examples of malfunction codes in this text are those which correspond to the Bally Slot codes. On some models, different codes are used. A cross reference chart is provided for your convenience (page 28).

Example:

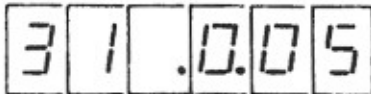
A 6-digit LED display showing the number 31.005. The digits are arranged in six boxes: the first shows '3', the second shows '1', the third shows a decimal point, the fourth shows '0', the fifth shows '0', and the sixth shows '5'.

The 31 in the first two columns in this example indicate a particular malfunction. (In this case a hopper jam.) The digits in the last three columns indicate the number of coins paid out before malfunction occurred.

3. The machine was in self-test #2 mode when power was turned off.

Example:

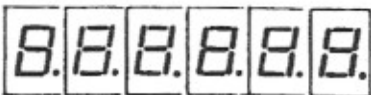
A 6-digit LED display showing the number 8.8.8.8.8.8. The digits are arranged in six boxes: the first shows '8', the second shows a decimal point, the third shows '8', the fourth shows a decimal point, the fifth shows '8', and the sixth shows '8'.

If 8's are present in all six columns for about one second, the machine will energize each lamp, coil and motor in a sequence determined by the features of that particular machine.
(SEE TEST #2 IN SECTION III)

If Personality PROM (M7) is not installed in the MPU Board, the following sequence will be observed on the display when power is applied:

* * * * * 6 briefly, then

6.5.4.3.2.1. for 1 second, then

8.8.8.8.8.8. for 1 second, repeat.

(See "CAUTION" on Page 7)

*Irrelevant Data for AS-2978-5, 6 or 7; Blank for AS-2978-3.

BUILT-IN TEST FUNCTIONS

The BALLY ELECTRONIC SLOT MACHINE is equipped with two types of test functions.

First, a diagnostic self-test on POWER UP. This test is primarily used to localize a problem in the MPU BOARD. These particular problems are discussed in detail in "MPU BOARD TEST STATION OPERATORS GUIDE AND TEST PROCEDURES":

FO-650-1 for MPU Board #AS-2978-3
FO-650-3 for MPU Board #AS-2978-5 or -6
FO-650-11 for MPU Board #AS-2978-7

Second, manual tests. All manual tests are initiated by using the TEST button on the hopper control board. The number of times the TEST button is pressed determines which test will be performed. The tests are numbered as follows:

1. START OF NEW GAME
2. COIL AND LAMP (LOAD) TEST
(See "CAUTION" on Page 7)
3. SWITCH TEST
4. HOPPER TEST
5. REEL READER TEST
6. PROGRAM TEST
7. METER DISPLAY TEST
8. GAME FUNCTIONAL TEST

NOTE: The Door Switch must be open to enter any manual test.

Closing the door while in TEST MODE, (decimal points in display) terminates the test in progress, indexes the reels and causes the display to read:

50 000

Closing the door has no effect if M7 is removed.



On the Series 1000, closing the door while in the TEST MODE (decimal points in display) shows this display.

INITIAL SET-UP (MAINTENANCE TESTS)

Performing the following procedure will assure the operator that the machine is operating properly before putting it out on location. If any problem is encountered while testing the machine, the entire procedure should be repeated. This will assure the operator that some previously tested part has not been affected while correcting another problem.

Step 1. "START of NEW GAME"

With the door open, turn the power switch ON. Near the front of the HOPPER unit is a printed circuit board with two push button switches located at the top. These switches are labeled RESET (left) and TEST (right). Press the TEST button ONE TIME ONLY, while observing the digital display.

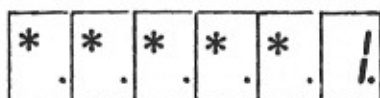

While button is depressed

*For MPU Board AS-2978-3, these digits are blank. For MPU Boards AS-2879-5, 6 & 7, these digits do not change from what was showing before the button was depressed.



For approximately one second after button is released, then . . .

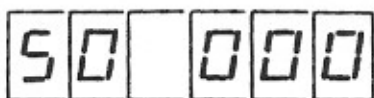

Remains until some action is taken such as closing door and playing machine, pressing TEST button, pressing RESET button, etc.

The DOOR OPEN lamp (in tower) is lit whenever door switch is open. COIN LOCKOUT is in effect while the machine is in any test mode. General illumination is lit whenever power is on. Closing door while in any self-test terminates it.

test continues



The wafer connectors on the boards are designated as "J" connections. A blackened area on a wafer, usually indicates a bad or dirty connection. This problem can be remedied by cleaning the offending point.

Step 2. LOAD TEST

Press TEST button two times.

CAUTION: DO NOT perform this test without personality PROM (M7) installed, as this would cause the hopper fuse to blow.

In this test, one OUTPUT (or LOAD) is energized each second. Closing the coin switch while in this test causes the CPU to stop sequencing, continuously energizing the LOAD that was active when the switch was closed.

0.0.0.0.0.2.

While button is depressed
(Zeroes are blank on AS-2978-3)

0.0.0.0.0.2.

For approximately one second
after button is released, then .

8.8.8.8.8.8.

1. (LED TEST)
Lit along with reel reader lamps
for approximately one second,
then . . .

Example:

2. . 1. 1. 0. 1.

2. (TILT lamp test)
Lit along with TILT lamp for
one second, then . . .

Example:

2. . 1. 1. 0. 4.

3. (DEPOSIT COIN lamp test)
Lit along with DEPOSIT COIN lamp
for one second, then continues
in this manner energizing each
lamp and coil (except hopper motor
and displaying associated code.

test continues



TEST SWITCH

Located on the Hopper Board, the push button TEST SWITCH, in conjunction with the LED display, is used to perform the Maintenance Tests described on pages 6-17. The six digit LED display is mounted on the front door at the right of the reel window.

RESET SWITCH

The game Reset Switch is located on the Hopper Board at the top right hand corner. Pushing this reset button often restarts the machine after there has been a minor malfunction.

At the end of each test cycle, the contents of the "LOAD TEST METER" indicating the number of times this test has been performed are displayed. The meter reading is displayed for approximately three seconds in the following format:

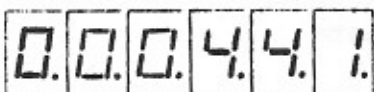
Example: 

This meter is incremented at the beginning of the test cycle and is not resettable.

After all loads have been tested, the CPU begins again at step 1 (LED test), continuing until test is terminated by either pressing the TEST button or closing the door.

Turning off power or pressing the RESET button while in this test causes the CPU to return to step 1 (LED test) and continue from that point. After the first step, the CPU is programmed to display a code as each output load is energized. This code is used by the technician to determine which circuit the CPU is activating, and takes the form:

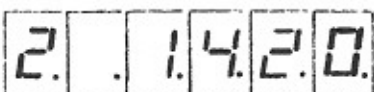
Example: 

The 2 in the first column shows that the game is in test mode #2. The 1 in the third column shows that the CPU is addressing IO Board #1 (standard IO for all games). The 4 in the fourth column shows that the CPU is addressing OUTPUT PORT #4. The 20 in the fifth and sixth columns shows that the CPU is activating the sixth circuit of the PORT. (PORT is defined to be a device which provides electrical access to a system or circuit. This system uses PORTS with six circuits or BITS, coded 01, 02, 04, 08, 10 and 20.)

test continues

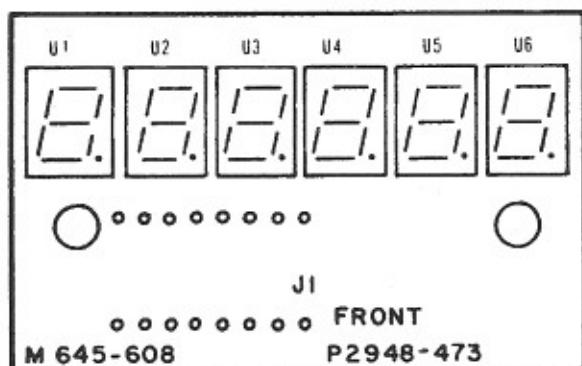

6-DIGET LED DISPLAY

The Display Board is located on the front door to the right of the reel window (see p. 60). Not only is it used for the test functions, but also to record the coins paid out and locate a machine malfunction. The rectangle display shown to the left is used on the 2000 Series. The one below, using small round windows, was utilized on the 1000 series.



1000 Series Led Display

AS-2985-2 DISPLAY BOARD ASSEMBLY		
SYMBOL	PART NO.	DESCRIPTION
J1		16 CONNECTOR FLAT CABLE - INSTALLED
U1-U6	E-680-11	LINTRONIX HD-1077R, 7 SEG, DISPLAY

Step 3. SWITCH TEST

Press TEST button three times.



While button is depressed

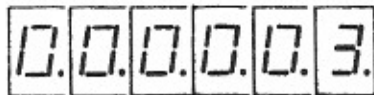

For approximately one second after button is released, then . . .

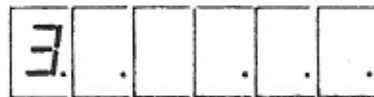

Until test is aborted or a switch is closed (a normally closed switch must be opened first)

Example:

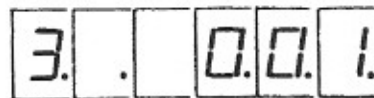

While coin switch held closed

Example:

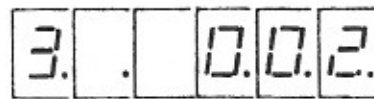

While hopper roller arm at rest (after lifting it once), until some other switch is actuated. Switches not included in test: Power Switch, Door Switch, Change Button Switch, TEST, RESET switches, Coin Return Switch on "IKE" Dollar Machines. For the code associated with each switch, see individual model information.

test continues

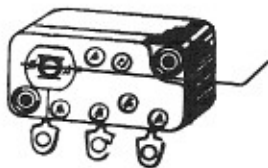

The COIN SWITCH is located on the inside of the Front Door immediately below the Coin Acceptor.

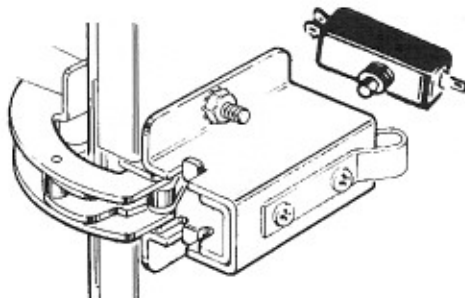

The DOOR SWITCH is located behind, and actuated by, the lower Door Hinge.

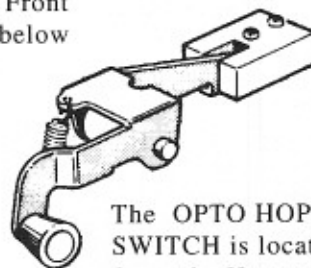

The OPTO HOPPER SWITCH is located above the Hopper Pin Wheel. On later models, the Opto Switch was replaced by a Micro Switch.



The LEVEL SWITCH is located at the base of the Hopper..

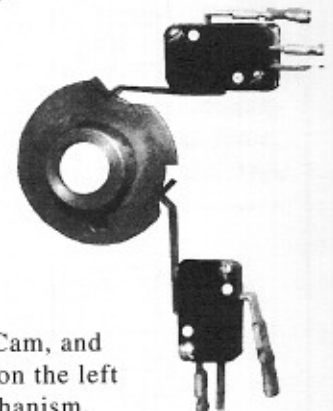

The ARM SWITCH, above the Cam, and the KICK SWITCH are located on the left Side Plate Assembly of the Mechanism.

INPUT CODE ASSIGNMENTS

See individual model information for additional switches.

<u>CODE</u>	<u>DESCRIPTION</u>
001	Coin Switch
002	Hopper Switch
004	Level Switch
*008	Door Switch (Hinge, Cam Series Comb
010	Kick Switch (Reel Mech)
020	Arm Switch (Reel Mech)

*Not displayed with personality PROM installed. Door switch closure terminates test.

Input Port #1 contains the reel reader inputs and normally closed coin switch input. This input (code 120) will be observed after SLOWLY releasing the coin switch. The reel reader inputs are test in step #5.

Input Ports #2 thru #4 are spare inputs for most models, except Bit #6 of Port 2 (Code 220) is used for the key switch.

The DIP Switches on the MPU Board are treated in a slightly different manner. They are read directly by the microprocessor chip, not thru an input port on the I.O. Board. The DIP switches are coded as follows:

<u>CODE</u>	<u>DESCRIPTION</u>
501	Switch #1
502	Switch #2
504	Switch #3
508	Switch #4
510	Switch #5
520	Switch #6
Not Used	Switch #7
Special Function	Switch #8

To determine the functions of the dip switches, see STANDARD OPTIONS section of this manual.

test continues

AN ESSENTIAL TOOL FOR BASIC REPAIRS



The Voltmeter (Multitester) is a must for working on SERIES E machines. Used as a continuity tester, it is useful for tracing circuits, locating bad soldering joints and for checking wires and Flat Cables for breaks. Using the voltage function, the meter is necessary for checking the voltage on the boards and in various circuitry.

An inexpensive model may be purchased for as low as \$20.

For difficult repairs consult your dealer,

Step 4. HOPPER TEST (10 Coin pay)

Press TEST button four times.

0.0.0.0.0.4.

While button is depressed
(Zeroes are blank on AS-2978-3)

0.0.0.0.0.4.

For approximately one second after
button is released, then . . .

4. . .0.0.0.

Until coins begin to pass under
roller, at which time the win meter
begins to increment, 001, 002, 003,
etc.

4. . .0.1.0.

When payout is complete (Hopper
Motor stops). At this time, the
winner paid lamp is lit.

If the processor detects a malfunction during this test, the hopper motor is stopped, feature lamps are flashed, the TILT lamp is lit and a code indicating the type of malfunction is flashed alternately with "coins in last game" (when in test mode, "coins in last game" is set to zero). The malfunction codes possible in this test are:

- 30 Hopper Override
- 31 Hopper Jam
- 32 Hopper Empty
- 33 Reset During Payout (Used on Series 1000 Only)

If power is turned off to service a malfunction, the test will be terminated when power is turned back on. If it is not necessary to turn off power, the RESET button may be used to terminate this test.

test continues

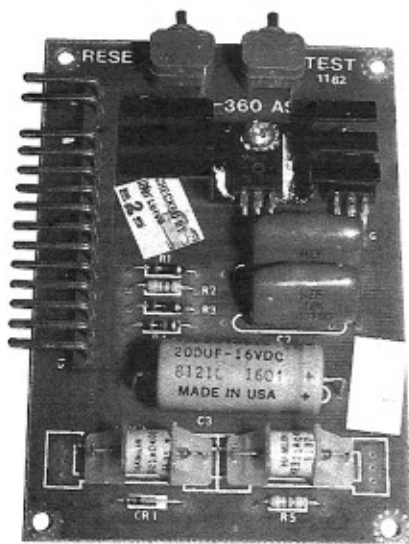

HOPPER BOARDS

The Series 1000 used the board on the left. The Series 2000, the board on the right. They are interchangeable by a minor one wire change. For more Hopper Board information see page 47.

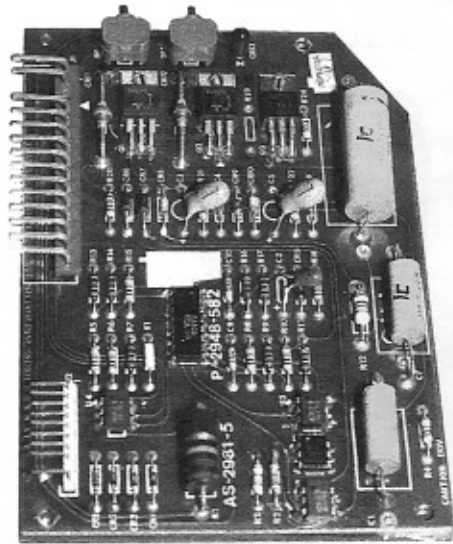

Step 5. REEL READER TEST

Press TEST button five times.

0.0.0.0.0.5

While button is depressed
(Zeroes are blank on AS-2978-3)

0.0.0.0.0.5

For approximately one second after
button is released, then . . .

1.c.3.4.*.*

Example:

Reel reader lamps light up.
Payline-For multiple payline
models, hold coin switch until
desired payline is displayed.

1.

c.

3.

4.

.*

Code for symbol appearing on
indicated payline, first reel.

Code for symbol appearing on
indicated payline, second reel.

Code for symbol appearing on
indicated payline of third reel.

For a 3 reel model, only decimal
point is displayed in these
positions. Codes for reel symbols
will be found on a label on the
front of the reel mech, as well
as in the individual model
information.

For additional Position Reader
information see page 46.

PAYLINES

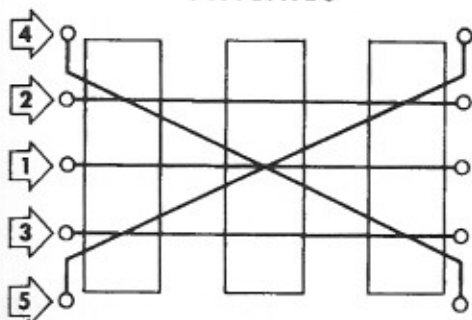

Note: Performing this test without Personality PROM installed
results in decimal position of reel being displayed
rather than symbol codes. (See FO-650-2: "PERIPHERAL
TEST STATION OPERATORS GUIDE AND TEST PROCEDURES").

Move each reel one position at a time while observing the display.
Check all positions on each reel. If the symbol appearing on
the indicated payline is at odds with the code being displayed,
check to be sure the correct tapes have been installed. If
the tapes are correct, proceed to the next test.

test continues



HOT TIP

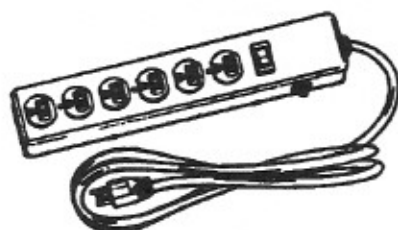

As with all electronic devices, it
is a very good idea to use a Surge
Protector to prevent the sensitive
electronic components against
house current surges.

Step 6. MEMORY CHECK

This test checks program memory and displays the "personality PROM" identification number, (which is listed on the Special Model Information Form) if the test is positive. This test is also performed each time the processor returns from reset or "power down". For the possible error conditions see section titled "POWER UP MALFUNCTION CODES".

Press TEST button six times.

0.0.0.0.0.6.

While button is depressed.
(Zeroes are blank on AS-2978-3)

0.0.0.0.0.6.

For approximately one second after
button is released, then . . .

Example:

0.0.0.1.9.7.

Personality PROM I.D. Number
is displayed.

Until test is terminated by
pressing RESET, TEST or Door
Switch.

Example:

5.6.4. . . 1.

If no Personality PROM installed,
ROM information is displayed
instead.

The 5 6 4 indicates program version
(in this example, version 5.64).
The 1 indicates "on-line" (SDS)
version. This position is blank
for "off-line" version.

Example:

5.6.7. . 5.5.

If no Personality PROM installed on the Series
1000, ROM information is displayed

test continues



HOT TIP

**PERSONALITY
PROM**

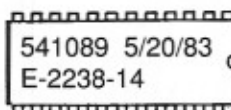

The payout percentage of a slot machine may be verified by pressing the Test Button a total of six times. It may also be confirmed, along with the model number of the machine, by checking the numbers on the Personality Prom located on the M.P.U. Board (see page 56).

Step 7. MAINTENANCE METER DISPLAY TEST

The Bally slot is equipped with a set of four meters intended to enhance the operator's maintenance program.

These meters, numbered 17 through 20, monitor:

17. **RESET METER** The number of times the processor has been caused to reset.
18. **MALFUNCTION METER** The number of malfunctions sensed by the processor.
19. **LOAD TEST METER** The number of times that TEST #2 has been performed.
20. **DOOR OPENED METER** The number of times the door has been opened.

To implement this test, press test button seven times.

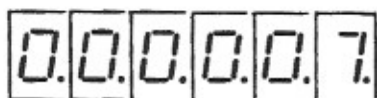

While button is depressed
(Zeroes are blank on AS-2978-3)

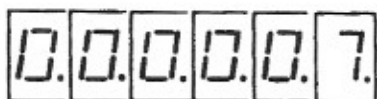

For approximately one second after
button is released, then . . .

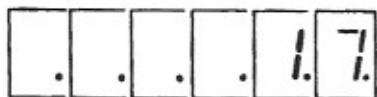

For one second,

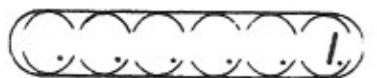

For one second, maintenance meter
number 1.

Example:



For six seconds, value in RESET
METER (counts number of times
processor has gone into reset
condition. MPU board circuitry
forces the processor to reset to
prevent erratic operation which
might be caused by static electric
or power fluctuations).

test continues



A BLOWN FUSE AND TROUBLESHOOTING

HOT TIP

A blown fuse, in conjunction with the P. C. Board schematics (pages 50, 51) and the fuse box diagram (page 63) can aid in isolating the circuit that caused the failure.



HOPPER FUSE WARNING LIGHT

A red lamp on the hopper lights when the fuse is blown. Replace it with a 5 amp 3AG fuse. If it blows a second time, check the Hopper components

For one second,

Example:

For six seconds, value in MALFUNCTION METER (counts number of times game malfunctions have caused machine to tilt).

For one second,

Example:

For six seconds, value in LOAD TEST METER. (Counts number of times self-test #2 has been performed).

For one second,

Example:

For six seconds, value in DOOR OPENED METER. (Counts number of times door has been opened).

Until some action is taken. Maintenance meter display routine has been completed and machine is conditioned for the start of the next game.

TO CONTINUE SERIES 1000 TESTS OMIT THE ABOVE AND CONTINUE WITH THE STEPS BELOW

For one second, maintenance meter number 2.

Example:

For six seconds, value in MALFUNCTION METER (counts number of times game malfunctions have caused machine to tilt).

For one second, maintenance meter number 3:

Example:

For six seconds, value in DOOR OPENED METER. (counts number of times door has been opened).

For one second, maintenance number 4:

Example:

For Six seconds, value in LOAD TEST METER. (counts number of times self-test #2 has been performed).

Until some action is taken. Maintenance meter display routine has been completed and machine is conditioned for the start of the next game.

Step 8. GAME FUNCTIONAL TEST

Press TEST button eight times.

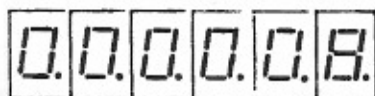
 While button is depressed
(Zeroes are blank on AS-2978-3)

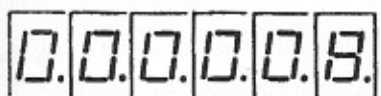
 For approximately one second
after button is released, then . . .

If Personality PROM (M7) is NOT installed, the display will fall into the sequence described on page 5.

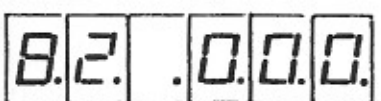
Example:  8 indicates Test #8 mode.
2 is current coins in. The slot machine is in the game function test, allowing normal operation except the reels may be set up for testing and any payout that occurs is displayed in the win meter but is not paid by the hopper and the winner paid lamp is not lit. Also, to simplify testing, the coin switch malfunction (See Page 27) is bypassed while in this test.

The game will remain in this test mode (decimal points on display) until it is terminated by a door switch or test button closure.

At this point all electronic functions have been tested. After performing routine mechanical inspection (slug rejection, proper lubrication of mechanical assemblies, proper reel kick and spin, etc.), the machine is ready to be placed on location.



BEAUPUG Beauplugs are the electric wire connectors that allow the Reel Mechanism (used only on the early Series 1000 slots, and the Hopper to be removed from the cabinet. To prevent damage to the Beauplugs remove these units carefully.

HOT TIP If there is a broken point on a Beaplug, Molex Connector or an Amp Plug, move the wire that is connected to the broken point to an unused point — if available.

AMP PLUGS They are similar in construction and repair to the Molex Connectors (page 36). Due to their ability to conduct low voltage circuits, Amp Plugs replaced the Beauplugs on the mechanisms on later Series 1000 and on all Series 2000 slots. These connectors are located in pairs on the rear side frame. New Beauplugs, Molex Connectors and Amp Plugs, along with the necessary tools, may be purchased from the Wico Corporation (see page 63).

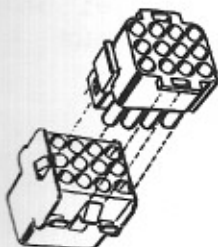

NORMAL OPERATION

With the exception of the 6-digit numerical display, there is no appreciable difference in the operation of the ELECTRONIC SLOT when compared with the electromechanical slot from the player's viewpoint.

The lighting of lamps, spinning and indexing of reels, payout, etc., follow the same pattern in both types of machines.

With the door closed, under regular game play, the display board presents two vital statistics, total in and total out count per individual game. The second digit from the left on the display indicates coin played last game. This count is updated at the indexing of reel number one each game*.

The digits in the 3rd, 4th, 5th and 6th columns of the display constitute the coins paid out during the last game. This count is zeroed on the display also at the indexing of reel number one of each game. If the door of the game is open, the door open malfunction code overrides the coins played count, but the coins paid value is still displayed. Performing any manual test causes both COIN IN and COIN OUT values to be set to zero.

The following is an example of two games (handle pulls), showing the operation of the display.

START

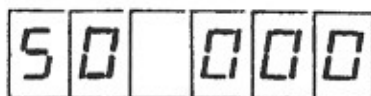

Player deposits one coin and pulls handle. Decimal points are turned off when handle is pulled.



This display is shown on Series 1,000 after a player deposits one coin and pulls the handle.

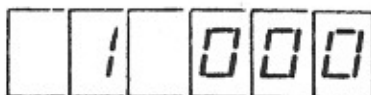

Coins in count displayed when first REEL indexes.

Assume cherries land on first and second REELS.

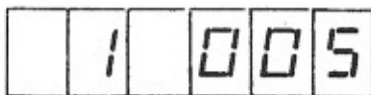

COINS OUT are displayed as they are dispensed from the hopper. At the end of payout (and this game), the display shows TOTAL coins in and coins out for this handle pull.

FIRST GAME COMPLETED

Player deposits three coins and pulls handle.

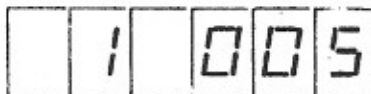

No change in display.

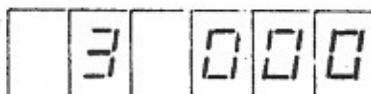

When first REEL indexes, COINS IN for this game replace COINS IN for previous game and COINS OUT value for previous game is set to zero.

Assume no winning combination.

SECOND GAME COMPLETED

NO CHANGE in display.

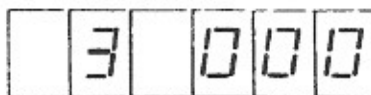

BOOKKEEPING METERS

The meter readings appear, one at a time, on the 6 digit display for about 6 seconds. Before each meter value is displayed, its assigned number is displayed for approximately one second. Numbers are assigned to the meters as follows*:

1. TOTAL IN
2. TOTAL OUT
3. CASH BOX
4. TOTAL GAMES PLAYED (HANDLE PULLS)

Meters one thru four are incremented according to their respective functions only with the door closed.

There are a total of 16 six digit meters available for display. The first four (five or six on models with attendant pays) are displayed with the door closed**.

The remaining meters are displayed by simply turning the door key counter clock-wise then actuating the key switch. These meters may monitor any condition specified, typically; number of 1 coin, 2 coin, 3 coin, etc. games played; number of 1st coin, 2nd coin, 3rd coin, etc. Jackpot wins that have occurred; and so on.

To determine which meters are used and the order in which they are displayed, refer to the FO-652-XXX form for the model in question.

The BOOKKEEPING METERS are displayed in the same manner as the MAINTENANCE METERS, described in SECTION III, step 7.

When the meter reading sequence is completed or if a reset occurs while reading meters, the reading sequence is terminated and the display is restored to the condition present before meter reading was started, unless the door was opened while meters were being displayed. In this case, the door open code will replace coins in count.

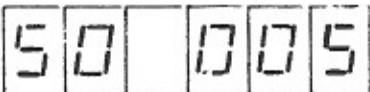
Example:  On Series 2000, 50 is door open code and 005 is the number of coins paid out in the last game.

* In some models, Maintenance Meter #20 (Door Openings) is also displayed as Bookkeeping Meter #0.

** In some models, all bookkeeping meters used are displayed with the door open or closed.

THE DISPLAYS BELOW REFER TO SERIES 1000 ONLY



If a reset occurs while reading meters, the reading sequence is terminated and the display takes this form.



Under normal conditions, when the meter reading sequence is completed, the display takes this form.

GAME CONDITION MALFUNCTION CODES

In the course of normal machine operation, the CPU is continuously monitoring conditions by sensing the INPUTS and comparing them with what the PROGRAM says they should be.

If the CPU detects a difference, it checks the PROGRAM to find out what to do next. Depending upon which INPUT is at fault, the PROGRAM instructs the CPU to take one or more of the following actions:

1. Display a MALFUNCTION CODE
(Excepting the Door Open code (50), all malfunction codes are flashed alternately with COINS IN information.)
2. Suspend play
3. Flash feature lamps
4. Light the TILT lamp

These actions are terminated by correcting the malfunction and pressing the RESET button.

Note: The TEST button is disabled while the machine is in the TILT mode to prevent disruption of a game in progress.

The following is an explanation of the standard MALFUNCTION CODES used:

1. COIN IN JAM - Play suspended, feature flashed, TILT lit.

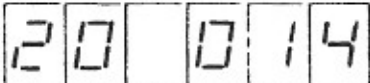
Example:  The 20 indicates a jam on the COIN SWITCH. The 014 equals coins paid out in previous game.

Flashing alternately with:

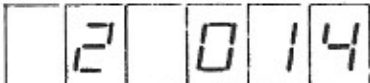
Example:  The 2 equals coins in for current game. Clearing the jam and pressing the RESET switch causes the feature lites to stop flashing.

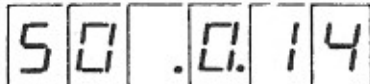
Example:  Door may now be closed and play resumed. Note: Any time the door is opened, the Display shows door open code. To see a malfunction code, actuate the KEY switch.

Note: Any time the RESET button is pressed, the center two decimal points are lit.

2. HOPPER OVERRIDE - Play suspended, feature flashed, TILT lit.

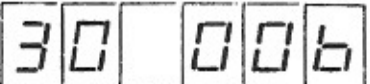
Example:  The 30 indicates that too many coins were dispensed by the hopper.

Flashing alternately with: 006 equals number of coins paid out for this pull of the handle.

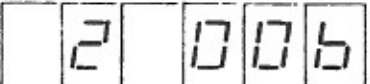
Example:  2 indicates coins played for current game. The 2 does not appear on Series 1000

Although the occurrence of this malfunction is unlikely, the possibility that it may happen does exist and will be detected by the machine. The fact that it requires a service call allows the technician to determine the cause (most likely mechanical in nature) and prevent it from recurring. Press RESET button to start next game.

3. HOPPER JAM - Play suspended, feature flashed, TILT lit.

Example: 

31 is the malfunction code.
003 is the number of coins paid out.

Flashing alternately with

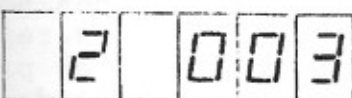
Example: 

The 2 is the number of coins in for the current game. It doesn't appear in the Series 1000.

Indicates a coin is stuck under the roller. To complete payout, clear jam and press the RESET button. The door must remain open until the TILT lamp lites, then goes out again (approx. 1 sec.), after which the operator has 3 secs. to close the door before payout resumes. Appropriate feature lites are lit before payout is completed.

4. HOPPER EMPTY - Play suspended, feature flashed, TILT lit.

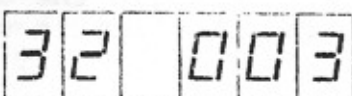
Example: 

Flashing alternately with:

Example: 

Indicates that the specified time limit has elapsed without a coin being detected. After determining and correcting the cause, follow the same procedure as described above to complete payout.

5. RESET DURING PAYOUT - Play suspended, TILT lit.

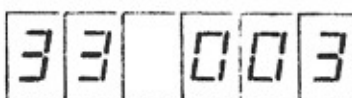
Example: 

Flashing alternately with:

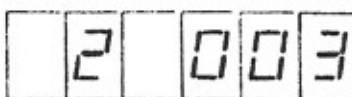
Example: 

This code appears when a reset occurs during payout. This can be caused by momentary power interruption, low line voltage, or static interference, any of which could cause the micro-processor to perform a faulty execution of program instructions. Entering the TILT mode prevents potentially disastrous results.

To complete the payout, follow the procedure described above for HOPPER JAM.

6. REEL HELD OR CANNOT BE READ - Play suspended, feature flashed, TILT lit.

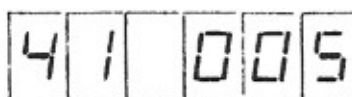
Example: 

Flashed alternately with:

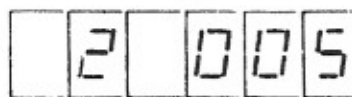
Example: 

The 2 is the number of coins played for this handle pull.

The 41 means the position reader on the 1st REEL has sensed one of the following (A) No motion, (B) 3 positional errors during this spin. 42 means the 2nd REEL is at fault; 43 means the 3rd REEL; 44 the 4th REEL and 45 the 5th REEL. The reels are numbered 1 thru 5, from left to right.

005 is the number of coins paid out in previous game. After determining and correcting the cause, spin by hand any non-indexed reels, press the RESET button and close the door to complete the game in progress. If necessary, the game may be terminated by pressing the TEST button one time.

Note: See Part 3 of standard options on Page 24.

7. DOOR OPEN - 5 second BUZZER alarm, Door Open Lamp (in tower) lit.

Example:

The 50 indicates the DOOR has been opened.

The DOOR OPEN lamp stays lit for as long as the door is open. Closing the door while in this state does not disturb the display. The 50 is replaced by the number of coins in for previous game when the handle is pulled.

Example:



If the door is closed on the Series 1000 while in MANUAL TEST mode, the display takes on the above display form.

Door opening is detected by the hinge switch or the lock cam switch. These switches are wired in series.

The BUZZER ALARM is activated for 5 seconds every minute while the door is open except during the time in which the machine is in a manual TEST mode.

Feature lamps flashing while this code is present means that some other malfunction has occurred. The KEY switch may be actuated to display the other malfunction information for as long as the KEY switch is held.

8. HANDLE PULLED WITH NO COINS IN Play suspended, feature flashed, TILT lit.

Example:

The 70 indicates there is a malfunction in the handle mechanism allowing the handle to be pulled with no coins played. Reels are not indexed because most causes of this condition are mechanical and, therefore, repetitive in nature.

Flashed alternately with:

Example:

The 0 indicates no coins have been played.

The 002 is the number of coins paid out last game.

9. ILLEGAL PLAY - DOOR OPEN Play suspended, feature flashed, TILT lit.
(KEY switch must be actuated to see this code)

Example:

The 70 indicates play has been attempted with the door open after Reel #1 indexed; 000, no coins paid out.

Flashed alternately with:

Example:

3 is the number of coins played for this game.

Note: This malfunction is sensed only when a jumper is installed from ground to J2, Pin 8 of I/O Board. (See Page 27 Item D)

10. REEL DID NOT INDEX - Play suspended, feature flashed, TILT lit.

Example:

7	1		0	0	0
---	---	--	---	---	---

Flashed alternately with:

Example:

	2		0	0	0
--	---	--	---	---	---

The 71 means the position reader on the 1st reel is not able to obtain a consistent reading. 72 means 2nd reel is at fault; 73, 3rd reel; 74, 4th reel; 75, 5th reel. If the reel in question is properly indexed, then this tilt indicates the reel has been moved since it was indexed. (This test is not performed in SDS (-1) program versions.) If the reel is not indexed, the cause for this malfunction is most likely mechanical. Self-test #2 (see page 7) may be used to verify the operation of the index coil. After the cause has been found and corrected, press the RESET button followed by depressing the TEST button once.

Note: See Jumper Selectable Options - Item D, on page 27.

11. POSITION ERRORS IN 2 OF LAST 8 SPINS - Play suspended, feature flashed, TILT lit.

Example:

9	1		0	0	5
---	---	--	---	---	---

Flashing alternately with:

Example:

	2		0	0	5
--	---	--	---	---	---

The 91 means the 1st Reel; 92 means 2nd Reel; 93, 3rd Reel; 94, 4th Reel; 95, 5th Reel. This tilt indicates that during the last 8 games there was a positional error during the spin of that reel in 2 of the 8 games.

Note: Displays for the previous Malfunction Codes (8. Handle Pulled With No Coins In, 9. Illegal Play—Door Open, 10. Reel Did Not Index, 11. Position Errors in 2 of the Last 8 Spins) appear also on Series 1000 LEDS that use Program Proms (M1, M2, M3) that are numbered 564 and above.

STANDARD OPTIONS

In addition to the usual options offered by Bally (custom glass, percentages, etc.), two more features are included in Bally's Electronic Slot Machine.

1. Switch selectable options.
2. Optional external connections.
3. Cable Jumper Selections.

1. Standard options which are selected by setting switches either to ON or to OFF have been incorporated into this system. More options are included in certain models. The switches are contained in a DIP (Dual In-Line Package) located in the lower right hand corner of the MPU Board.

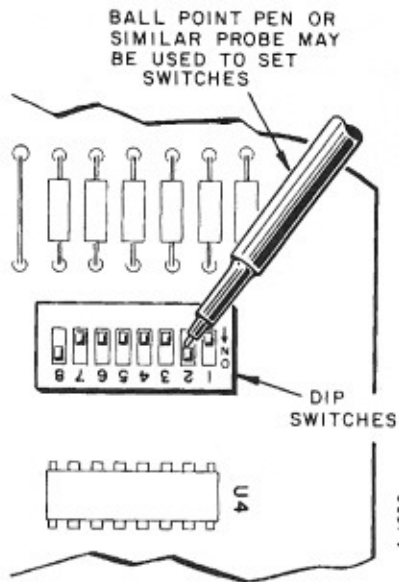

SWITCH NO.	ON	OFF
1	Jackpot Bell (continuous signal)	Jackpot Gong (pulsed signal)
2	See Individual Model Information	
3		
4		
5		
6	Not used	
7		
8	Must be ON in game operation	Only when trouble- shooting MPU Board.

2. A terminal block is provided with the following standard connections:

Typical Circuit Connections

Terminal Block is located on the back wall of the cabinet behind the Hopper.

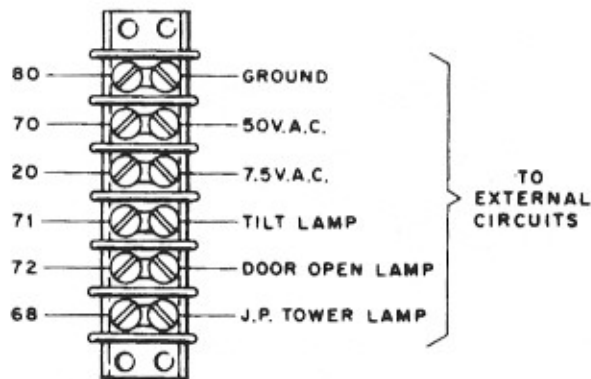

Where a lamp is used in the machine, any external device connected to that the corresponding wire MUST be a 6 volt device.

Additional connections can be supplied upon request to meet your special requirements.

For any additions or exceptions to the above diagram, see the GAME WIRING DIAGRAM & PLUG WIRING INFO supplied with each machine.

3. JUMPER SELECTABLE OPTIONS

A) TILT CODE SELECT

With a jumper installed from J3, Pin 20 of the I/O Board to ground (J1, Pin 28), the Bally Slot Malfunction Codes are used. With this jumper removed, the SDS malfunction exception codes are used. (See Page 26)

B) SPIN CONTROL SELECT

With a jumper installed from J3, Pin 16 of the I/O Board to ground (J3, Pin 7), current game is nullified upon pressing the RESET button while a 4X malfunction is present.

C) REEL SPIN TIME VARIATIONS

In some locations it is desirable for the reels to spin for a shorter or longer period of time than that set at the factory. To allow for this flexibility, three diodes may be installed on the Reel Reader Control Board. By installing one or more of these diodes various timing combinations may be obtained as described below.

DIODE INSTALLED	NO DIODE	FUNCTION	WHAT IS AFFECTED
	CR1	Short	Max. Variation Time of All Reels
CR1		Long	
	CR2 & 3	Med. Long	Spin Time of Reel #1
CR2	CR3	Long	
CR3	CR2	Med. Short *	
CR2 & 3		Short *	

* Long for Atlantic City Models

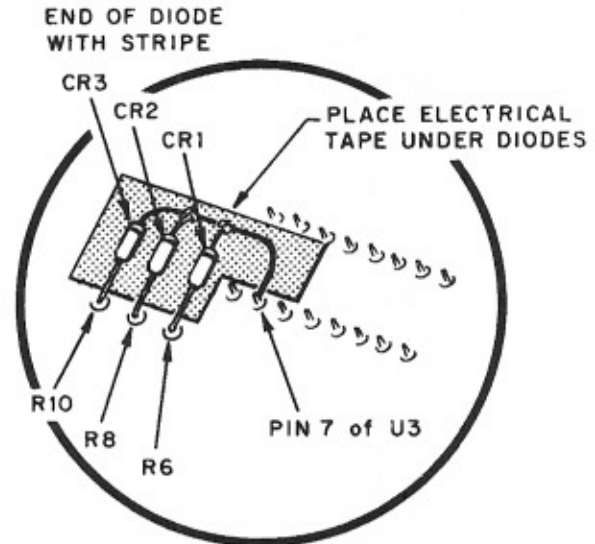

Back Side of AS-2983-1 Reel Reader Control Board

All Diodes are 1N4148 Type
Bally P/N E-587-014

Machines produced after December, 1982 are equipped with Dip Switches on the Reel Reader Control Board (AS-2983-2) to provide these functions.

By setting these switches, various timing combinations may be obtained as described below:

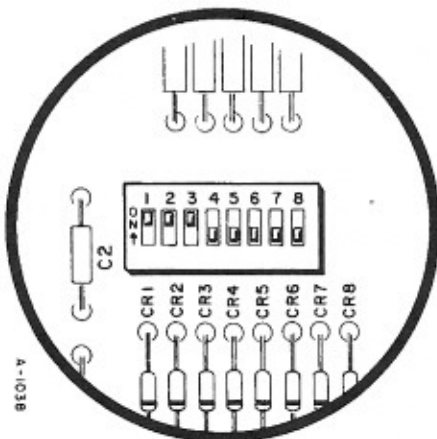

SWITCH NO.		FUNCTION	
ON	OFF		
	1	Short	Max. Variation (all Reels)
1		Long	
	2 & 3	Med. Long	Spin Time (Reel #1)
2	3	Long	
3	2	Med. Short	
2 & 3		Short	

Note: Switches #4 thru #8 are reserved for future use.

GAME CONDITION — QUICK REFERENCE — MALFUNCTION CODES

CODE	DESCRIPTION	CODE	DESCRIPTION
20	Coin switch jam	71	Spinning after indexing - Reel #1
30	Too many coins dispensed	72	Spinning after indexing - Reel #2
31	Hopper jam (Roller arm up too long)	73	Spinning after indexing - Reel #3
32	Hopper empty (Roller arm down too long)	74	Spinning after indexing - Reel #4
33	Reset occurred during payout	75	Spinning after indexing - Reel #5
41	Improper spin (Reel held, etc.) - Reel #1	91	Position error (2 of last 8 spins) - Reel #1
42	Improper spin (Reel held, etc.) - Reel #2	92	Position error (2 of last 8 spins) - Reel #2
43	Improper spin (Reel held, etc.) - Reel #3	93	Position error (2 of last 8 spins) - Reel #3
44	Improper spin (Reel held, etc.) - Reel #4	94	Position error (2 of last 8 spins) - Reel #4
45	Improper spin (Reel held, etc.) - Reel #5	95	Position error (2 of last 8 spins) - Reel #5
50	Door has been opened	For a detailed explanation see pages 20-23 * This condition not applicable to games with a Replay Register or Atlantic City Models.	
70	Illegal handle pull (No coins played) ; or		
70	Illegal game (Coins played, door open)*		

POWER UP MALFUNCTION CODES SERIES 1000

The M.P.U. Board Circuitry is configured in a way that directs the microprocessor to access an area of memory which is programmed to conduct a brief self-test of basic circuit functions when power is applied.

This is referred to as "Power Up Self Test." If during this test, the processor detects a circuit failure, it is programmed to output to the display a code indicating which circuit is at fault. The codes are as follows;



"Watch Dog"
circuit failure



Memory test failure



Ram failure
Mode #1 (Normal)

For one second
only, followed by:



Ram failure
Mode #1 (Safe)

Example

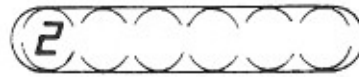

Indicating which
memory chip is at
fault (M1, M2, M3
or M7)



Incorrect or
no second ROM



No clocked
interrupts



Incorrect or
no third ROM



No zero crossing
interrupts



Incorrect PROM
series

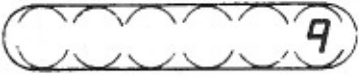

Interrupt line (any)
held low

The number of each test is displayed as above while the processor is performing the test, but tests #1 thru #5 and #9 occur so quickly that the eye cannot detect them.

MISCELLANEOUS FEATURES

EXTRA COIN

The electronic slot is also designed to detect an over coining situation. If an extra coin, one more than the specified coin limit of the game, were to cross the coin switch, it would be shown on the display after the first reel indexes and would act as the first coin deposited for the next game. Where a Replay Register (Credit Meter) is used, the additional coin will be applied to the Credit Meter immediately and to the "Coins In" verification meter at the start of the next game.

KEY SWITCH

Another feature involving the display is that meter readings may be obtained by casino personnel without opening the door. This is accomplished by inserting and turning a key in the lock on the right side of the machine before the first coin of a new game is inserted. (On a Replay Register game, credits must be cleared from the Replay Register before meter readings can be taken). Upon conclusion of the meter display routine normal game operation will resume. This key switch serves another purpose on games with attendant paid jackpots. When the machine is in a lock-up condition, the actuation of this switch yields a jackpot cancel routine.

JACKPOT LOCK-UP

For Jackpot payouts too large to be paid from the hopper, the machine is rendered unplayable until the Key Switch is actuated. During this time, the Jackpot Bell rings, Jackpot tower lamp is lit, and when applicable, Attendant Pay lamp is lit, SDS signal is output, appropriate feature lites are lit or flashed. When the Key Switch is actuated, the Winner Paid and Insert Coin lamps are lit, feature lites stop flashing and coins are accepted. The bell continues to ring and Jackpot lamps remain lit till a coin is deposited, at which time normal play resumes. Any variations to this sequence will be described in the Special Model Information Form (FO-652-XXX) accompanying each machine.

DOOR OPEN OPTION

NEVADA GAME CONTROL

With a jumper installed from J2, Pin 8 of the I/O Board to ground, attempting to play a game with the door open will result in a TILT. The door open code will be present on the display and the feature lites will be flashing. The tilt code (70 alternating with coins played count) will appear on the display while the key switch is held. This condition will occur after all reels have indexed if the door has been opened after reel #1 is stopped. With no jumper installed in this position, normal play sequence is not disturbed, regardless of door position.

SERVICE & ADJUSTMENTS

INTERNAL SERVICE & ADJUSTMENTS

For good service access to the internal working parts, remove the Reel Unit. Now wipe off excess grease and grime. The Unit can now be lightly lubricated with our lubriplate #1 Oil. Slides and units with heavy duty loads can be lightly greased using our Hydrotex Lube #651.

With the Reel Mech out of the cabinet, it can be operated with a Reel Mechanism Test Handle (Pt. No. K-574, available thru the Bally Service Dept.) You can easily see if the Trip Operating Lever Pawl is tripping off the Stop Bracket at the correct moment (see Figure 1). The Stop Bracket Adjustment can be checked by observing the action of the Toggle Levers as the Handle is slowly pulled.

The following illustrations show the Right Side of the Reel Mechanism in the 3 positions prior to Kick-off. These illustrations show the factory standard average settings of the Stop Bracket (Trip Arm) & Drive Shaft (Trip Arm). Also shown are the centerline dimensions and operating distances of various levers & Shafts (as per engineering design). It should be noted that because of variations in tolerances, these given dimensions are a general guide and may need calibrating when working on an individual machine.

REST POSITION ADJUSTMENT

The illustration (Figure 1) of the Reel Mechanism is shown in a rest position with all adjustments completed for a proper operating mechanism. The dimensions shown are reference points for checking an adjusted unit.

Set the reel mechanism on a flat surface. The setting to be made is the height of the Roller Stud on the Gear Assembly. When checking the dimension be sure the Link is against Stop Bracket (Link) at rear of cylinder.

To make this adjustment, turn the Elastic Stop Nut (outer) on the Drive Shaft of the Trip Operating Lever to obtain a $1-11/16$ " dimension shown.

The Elastic Stop Nut (Inner) is now adjusted to give approximately $1/16$ " of play between nut and coupling as shown.

Note: under certain conditions the $1/16$ " play may not apply.

STOP BRACKET ADJUSTMENT

The next setting to be made is the Stop Bracket (Trip Arm). This is done by moving the bracket to a position when measured, that should read approximately $1-15/16$ " from the end of the Side Plate to the inside form of bracket (see Figure 1).

If the Stop Bracket is set back too far the Trip Arm will fire off before the toggles are locked up (Latch Pawl) causing an uncoordinated reel spin. If the Stop Bracket is set forward too far the Trip Operating Lever Pawl cannot trip off the Stop Bracket because the Handle is in a full "down" position (full stroke limit). At this time the Handle will stick in a down position until a Service Man opens the Machine and manually releases the Trip Pawl.

The setting of the Stop Bracket (Trip Arm) is extremely critical

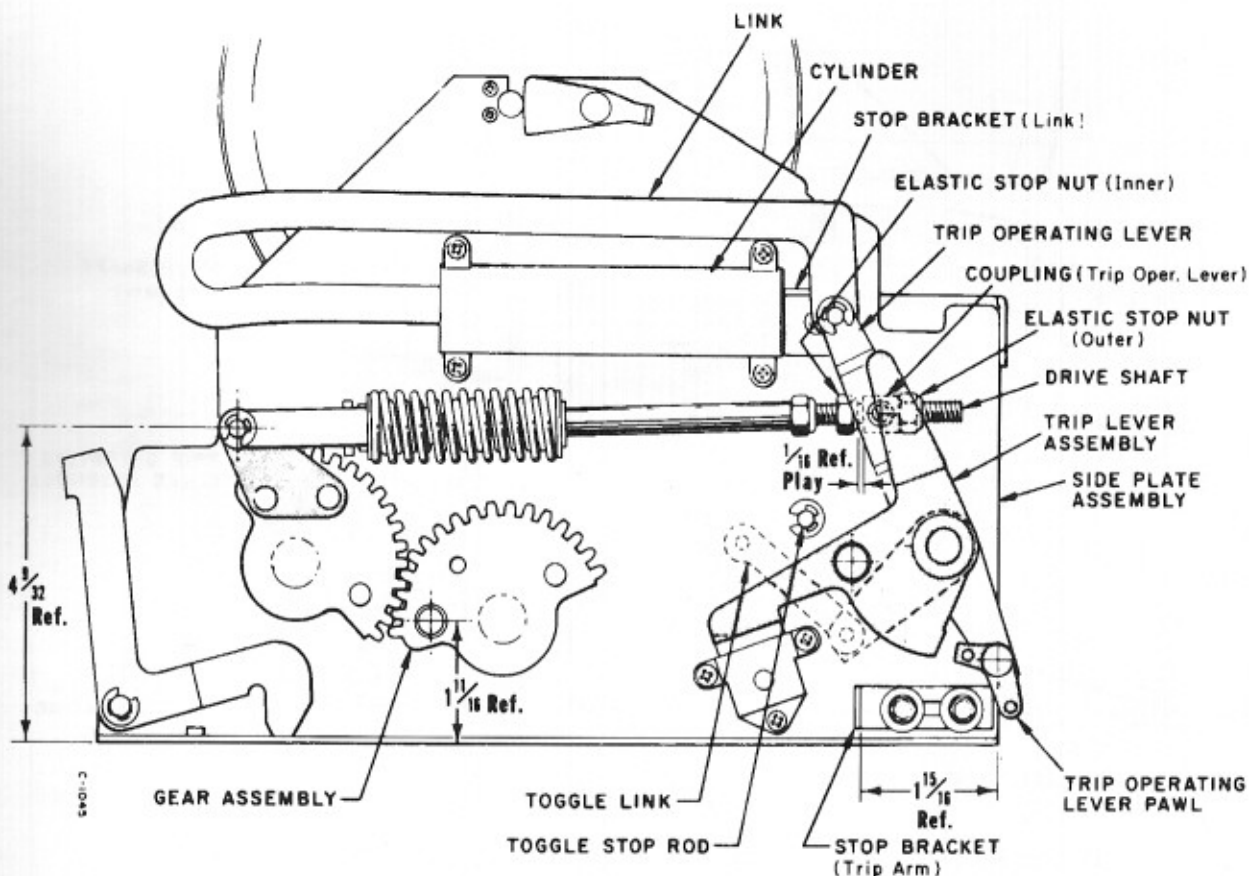

Figure 1. Reel Mechanism in Rest Position

for a proper kick-off and spin. As you see in the Reel Mechanism's Trip Position (Figure 3), the Toggle Levers are in a "full up" position against the Toggle Stop Rod and the Latch Pawl has moved under the Toggle Levers to just touch the Toggle Stop Rod Locking the Toggles in an "up" position (in turn cocking back the Index Levers which release the Reels). Also notice that the Trip Operating Lever Pawl is against the Stop Bracket and ready to fire off. This is the correct Stop Bracket adjustment position.

DRIVE SHAFT ADJUSTMENT

The Trip Arm Drive Shaft Adjustment is factory set according to the dimensions shown in Figure 1. This setting gives a full stroke to the Trip Operating Lever and aligns the roller stud (actuating

Gear) with the Handle Mech. Actuating Arm. The alignment into the Handle Mech. Actuating Arm is essential so that the Handle Mechanism's full stroke actuation corresponds to the Trip Operating Levers full stroke actuation and trip-off. When installing a Reel Mech. back into the Cabinet see that the Roller Stud aligns perfectly with the Handle Mech. Actuating Arm.

START MOTION POSITION ADJUSTMENT

The Start Motion Position (Fig. 2) shows the starting movement of the Gear Assembly, Shaft Assembly and Trip Operating Lever Assembly Pawl until making contact with Trip Lever Assembly. At this point the internal mechanism's cycle begins its motion for cocking the Reels.

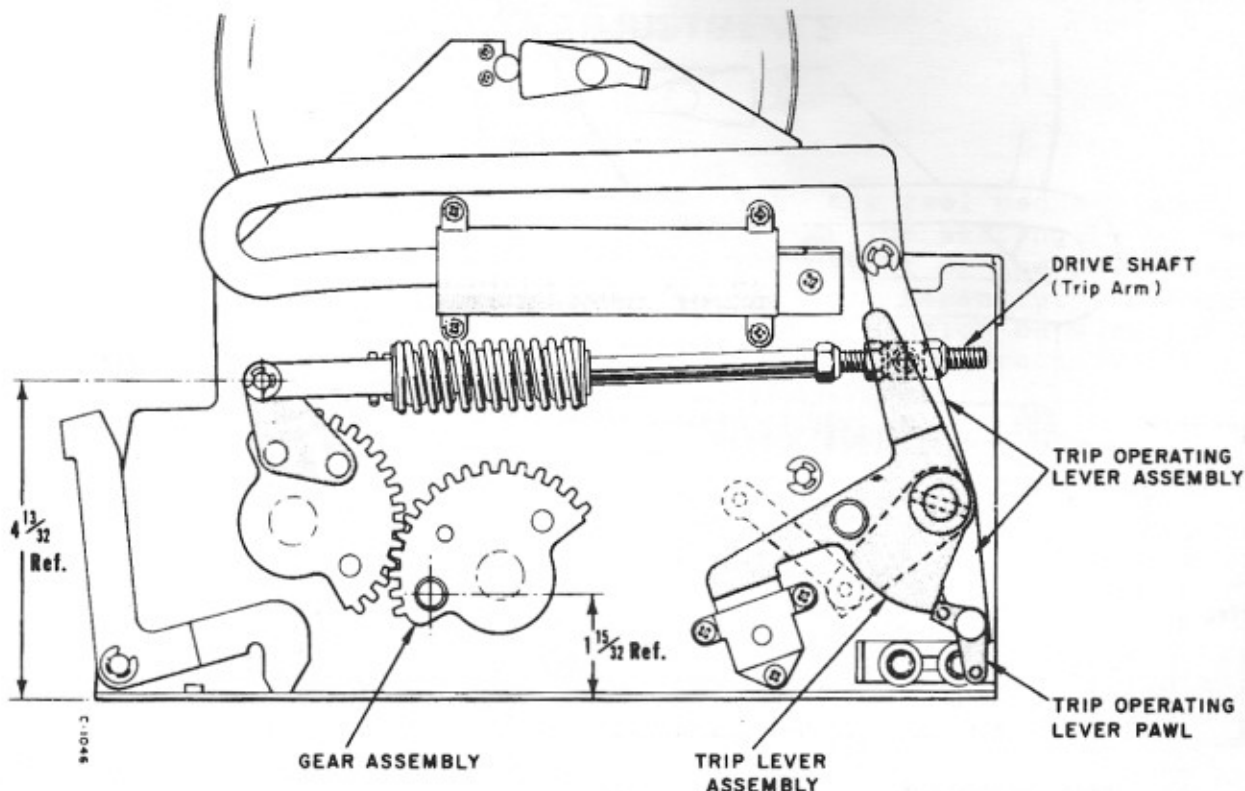

Figure 2. Reel Mechanism in Start Motion Position

TRIP POSITION ADJUSTMENT

The Trip Position (Figure 3) shows the cocked mechanism just at the time of tripping the Trip Operating Lever Pawl which in turn fires the Drive Lever (not shown) to spin the Reels and unlatch the Latch Pawl Assembly.

CYCLE TIMING SEQUENCE

The cycle timing is sequenced as follows: As the Handle is pulled, the Trip Operating Pawl contacts the Trip Lever and rotates it clockwise. Being pinned to the Trip Shaft, it rotates all of the Crank Assemblies which are also pinned to the Trip Shaft. These Crank Assemblies lift the Toggle Lever upward and as they pass the notch on the Latch Pawls the springs pull the Latch Pawls under the Toggle Lever.

Further rotation gives the proper overtravel to allow completion of all motion and positive latch. The further rotation also brings the Toggle Levers up to just touch the Toggle Stop Rod. At this exact moment, the Trip Operating Pawl is pulled off by the Stop Bracket and the trip off is accomplished, resulting in spin of the reels.

REEL MECH. TO HANDLE MECH. TIMING

When all bench adjustments are made to the Reel Mechanism we must now insure proper relationship of timing the Reel Mech to the Handle Mechanism in the cabinet. The Handle Mechanism is designed with two features directly related to the Reel Mechanism; the Full Stroke Pawl which insures against reversal of handle movement until trip of reels and the Secondary

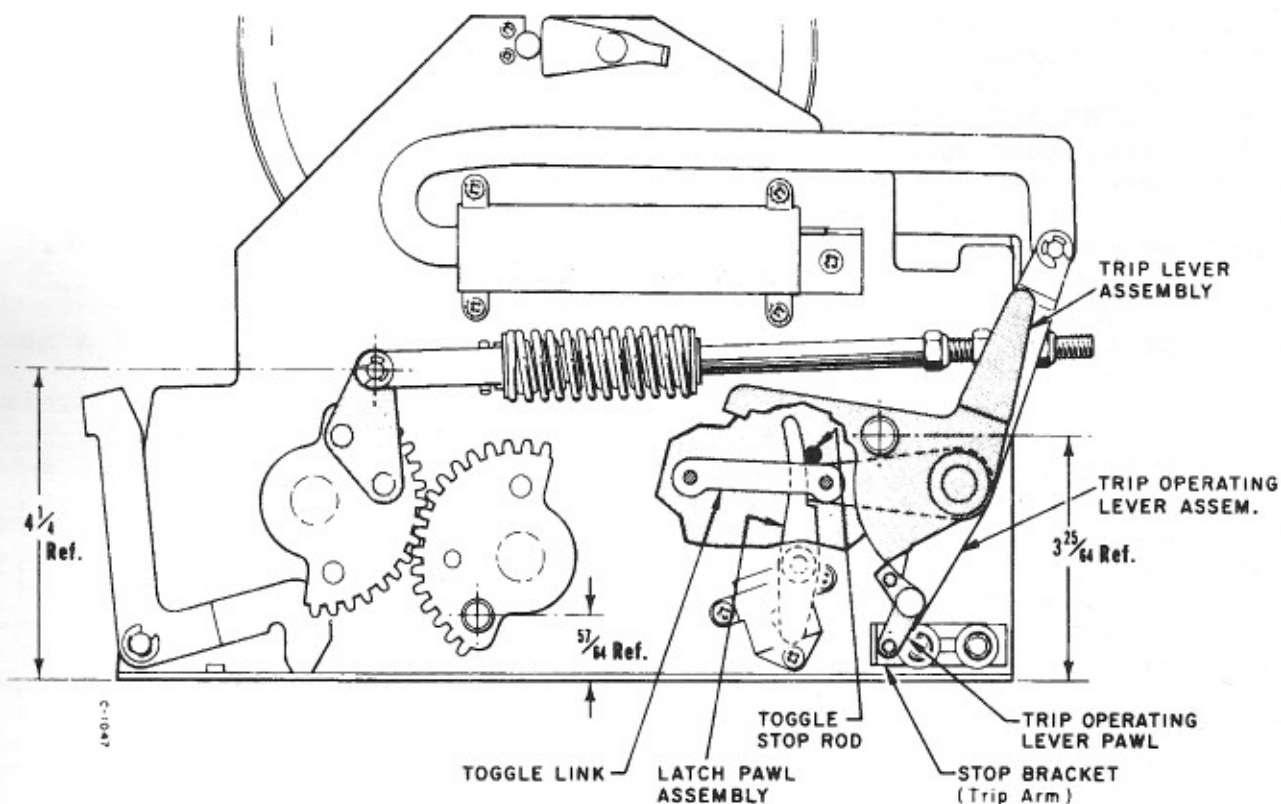

Figure 3. Reel Mechanism in Trip Position

Latch which locks the Handle in the pulled position until the Reel Mechanism has tripped.

With the Reel Mechanism in place and locked into position, the Handle can be pulled by manually holding the release arm at the top of the Handle Mechanism. By pulling the Handle very slowly you can check to make sure that the Full Stroke Pawl on the Handle Mechanism does not reverse and release until the Reel Mechanism has tripped.

If this does not occur, you must remove the Reel Mechanism from the cabinet and set the center nut on the Drive Shaft slightly toward the rear to insure simultaneous trip with release of pawl.

The second timing then corrects itself to release the secondary latch with the trip of the Reel Mechanism.

AIR CYLINDER OPERATION and SERVICE

The function of the Air Cylinder is to insure a slight delay during a fast handle pull to allow the Toggle Links to overtravel and become held in the "latched" position by the Latch Pawl Assemblies. This slight delay gives time for the reaction of the related parts to fully function, i.e., springs to pull latches under Toggle Link and Lever Assemblies.

Fast pull is also resulting in holding back motion of the Drive Shaft by the Air Cylinder. This compresses the Spring Assembly in the Drive Arm during the slight delay and these springs then complete the motion and insure proper function.

If it appears there is undue resistance to a Handle Pull, check to see if the tiny hole

in the end of Cylinder (center) is plugged (causing compression resistance). If it appears there is no delay action to cushion hard, fast handle pulls, you may need a new Piston Cup Seal. The Piston Cylinder should be greased occasionally.

It is very important that this Unit function correctly to insure latch of toggles and proper spin and index.

REEL UNIT OPERATION and SERVICE

The Reel Units should spin smoothly and freely on the Shaft with no resistance. They should also spin straight and true with no warpage or wobble.

The Reel Hubs are equipped with Needle Bearings for top performance and long life. Lubricate this Hub Unit (note hole) occasionally with a drop of our Lubriplate No. 1 Oil, then wipe the Unit off to prevent any oil spin-off on the Reel Tapes.

You will also notice a Screw Operated Brake on the Hub. At the present time factory adjusted machines do not use the Brakes. It is felt that a good spin gives the best reel symbol mix. However the Braking Screw has certain applications where Reel Speed control is desired.

In 1973 Bally introduced a new stainless steel, anti-magnetic reel as standard equipment. This Reel is now available as a replacement part from Bally Parts and Service. When re-installing or replacing reel Tapes be sure they are securely fastened. The Reel tapes are plastic laminated and have a very tough smooth surface which is virtually stain proof and indestructible. Because of the very slick surface, the Tape must be properly clamped down in the Reel gripping edge or slippage can occur. Any slippage can throw off the relationship of the Symbol to the Index Wheel causing a confused payout pattern.

----- ELECTRICAL ADJUSTMENTS -----

REEL READER ASSEMBLY ADJUSTMENT

The electronic Reel Mech offers an optical reading system which requires proper positioning of the Reel Reader Assemblies to their respective Index Wheels. To accomplish this adjustment, simply loosen the 2 mounting screws holding the Reader assembly to the Reel Front Plate (see Figure 4). Position the Index Wheel (as indicated in Figure 4) and retighten the mounting screws. Repeat this operation for each Reel Reader Assembly used, 3 times for a 3 Reel game, 4 times for a 4 Reel, etc.

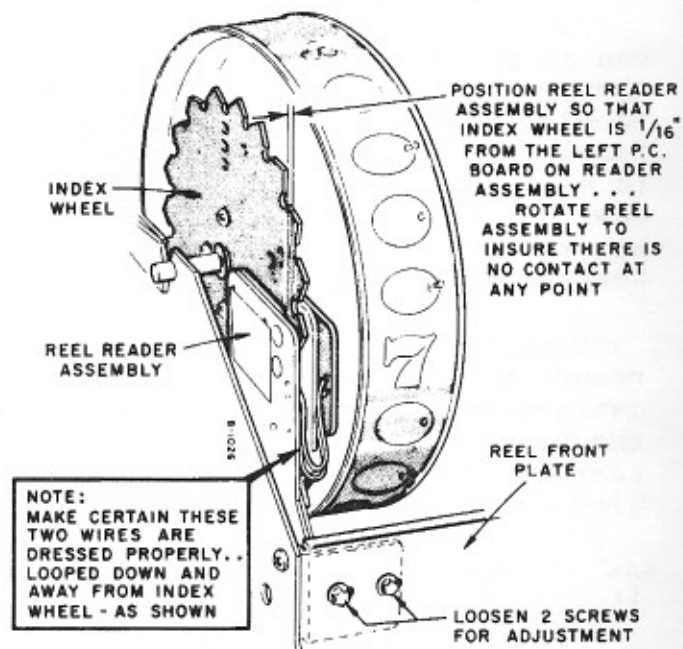

FIGURE 4.
Reel Reader Assembly Adjustment

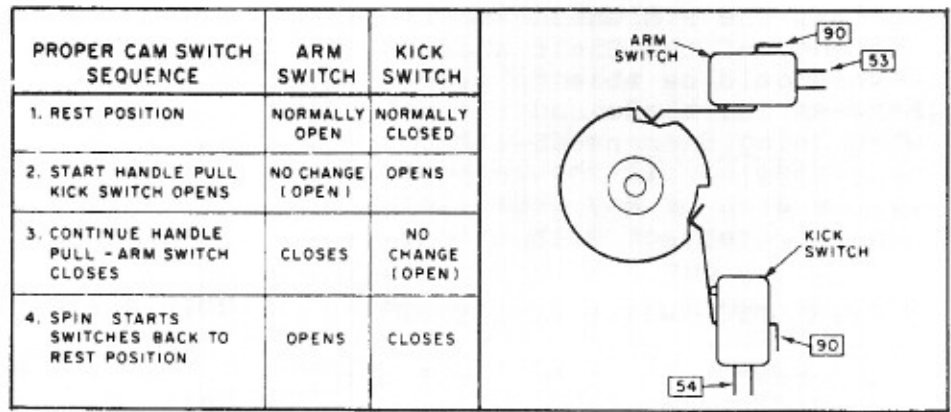
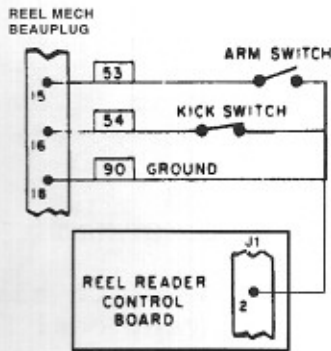

Figure 5. Cam Switch Sequence

CAM SWITCH TIMING

Also, the electronic Reel Mech incorporates a Cam Switch timing which is quite simple to adjust. All that is needed for this adjustment is the loosening of the Reel Mech Cam (located on the L.H. Side Plate) and moving it to conform with the proper sequencing of the Cam Switches. Proper sequencing of the Cam Switches for electronic games is described as follows:

Arm Switch - 53 Wire
Wired Normally Open Switch

Kick Switch - 54 Wire
Wired Normally Closed Switch

The states of these two switches from rest position through one game cycle, back to rest position again, are described in Figure 5 showing the proper switch-cam relationships.

----- HOPPER PAYOUT UNIT SERVICE & ADJUSTMENTS -----

For a complete overhaul of the Hopper Payout Unit, remove the Unit from the game and remove the scoop cover. Now follow the general point by point procedure.

A good cleaning of the unit is in order. An aerosol type degreaser or contact cleaner can be used, however, all parts must be wiped off with a clean cloth to remove any residue and dissolved scum.

After cleaning the Hopper Unit, we can inspect and adjust the Hopper in the following order:

HOPPER WIPER ADJUSTMENT

Adjust wiper so that clearance between pin wheel & wiper will allow a single coin to pass.

POSITION OF HOPPER KNIFE

Check the Hopper Knife (see Fig. 6). The forward edge must be

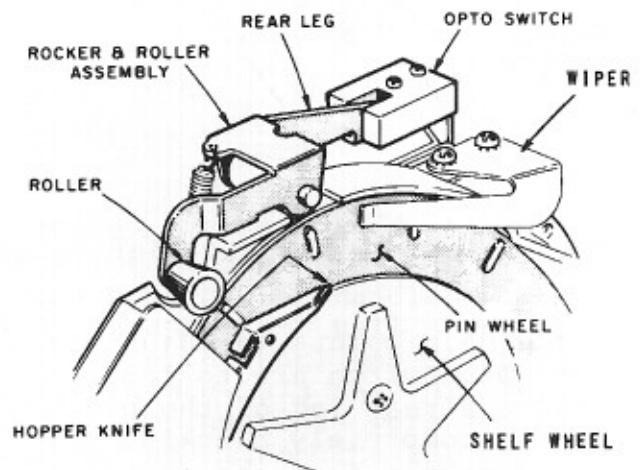

Figure 6. Hopper Knife Position

against the Pin Wheel and touching the edge of the Shelf Wheel. No coin should be able to wedge itself between the blade and the coin disc when being dispensed. Absolutely no grease or oil should be applied to the area or any other area that comes in contact with coins.

HOPPER OPTO-SWITCH ADJUSTMENT

The next item to be checked & adjusted is the Hopper Opto-Switch. This Opto-Switch does the actual coin counting as coins move out under the roller of the Rocker & Roller Assembly. The pivot action of the Roller Assy. allows the rear leg of the roller assembly to be removed from in between the light emitting source and photo transistor of the Opto-Switch. Each transition from light blocking, to Opto-Switch operation by removing pivot arm from light path, back to light blocking, records one coin-out pulse (See Figure 7).

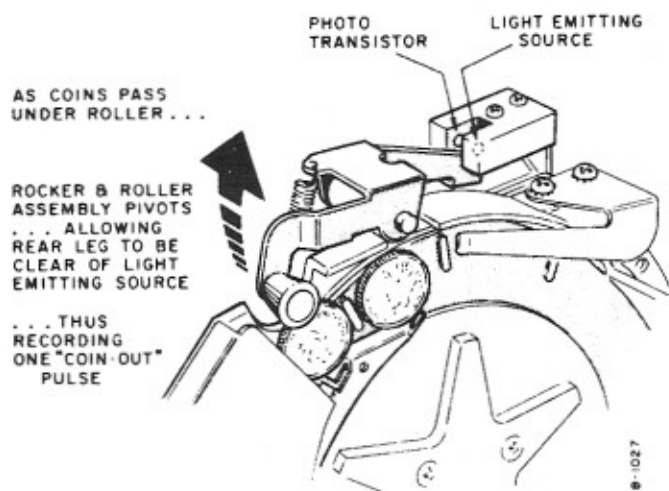

Figure 7
Hopper Opto-Switch (Earlier Models)

The main points in adjusting the Opto-Switch are to insure that the rear leg of the pivot arm is completely blocking the light source from the photo-transistor of the Opto-Switch when the arm is at rest, and the leg is completely out of

the way of the Opto-Switch as a coin passes under the roller. These conditions can be had by either slightly increasing or decreasing the form on the Opto-Switch mounting bracket to allow proper pivot arm-to-light source clearance.

HOPPER MICRO SWITCH ADJUSTMENT

The old Hopper Opto-Switch has been replaced by a conventional Micro-Switch to allow for more precise adjustment. The switch contacts are of the low current capability, gold-crosspoint nature.

Adjustment on this new switch is quite simple. Loosen the nut on the rocker and roller assembly, screw the adjustment screw down to within 1/32" of the switch actuator blade and then re-tighten the nut. (See Figure 8)

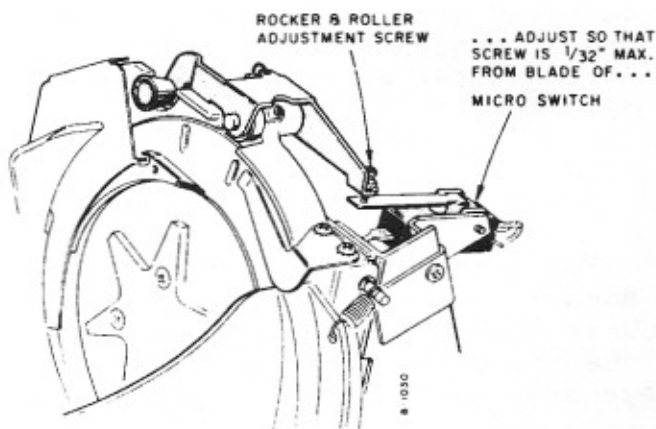

Figure 8
Hopper Micro-Switch (Later Models)

Check the switch with an actual coin under the roller arm to insure a positive switch actuation. Also, make sure that the switch is at a rest position when no coin is present under the roller.

Detecting the coin earlier or later as it passes under the roller is controlled by the screw adjustment on the rocker and roller arm assembly. Bending the switch actuator is not necessary.

ROCKER PIN SET SCREW ADJUSTMENT

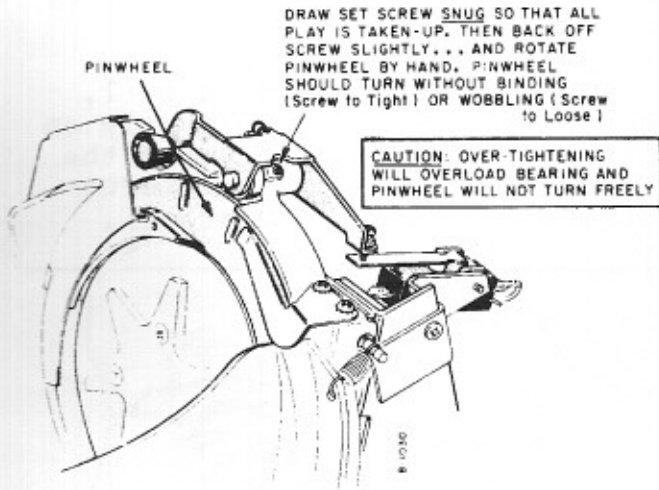

Figure 9. Rocker Pin Adjustment

HOPPER COIN CONVERSION

Coins of diameter .669 to 1.115 use parts; Pin Wheel P-842 (16 Pins), Shelf Wheel P-847 (specify coin). In the conversion to the Dollar, the Coin Spider Assy. A-3750 is deleted, and replaced with a Drive Bushing S-231-826 and Screw LSPR-1032-1116. Pin Wheel P-842-1 (12 Pins) is used for all coin diameter 1.120 to 1.500 Shelf Wheel P-847-6 is used for the Dollar coin along with a new Agitator, R-526. A Hopper liner P-834 is also added to the Hopper for the large Dollar coins.

HOPPER COUNTER BALANCE ADJUSTMENT

Adjustment is made by first filling the Hopper with the desired level of coins. Then start the adjustment with the Micro-Switch in the up position (see Fig. 10). Adjust Set Screw screwed into a clockwise position. Now back off Set Screw counter-clockwise very gradually until Micro Switch clicks into the down position. Now Hopper is set at the given desired capacity.

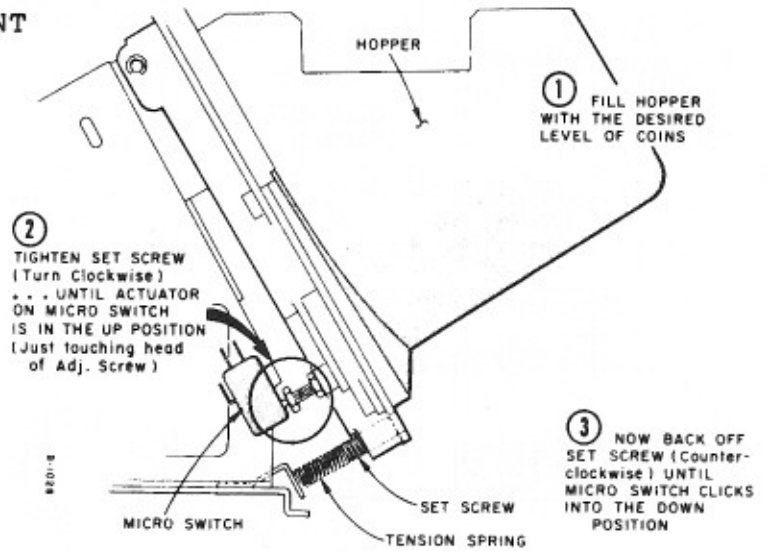

Figure 10. Hopper Counter Balance Adjustment

----- HANDLE MECHANISM SERVICE -----

It is the Handle Mechanism which initially receives the impact of a hard Handle pull. Because of the tough requirements, this unit must be of the strongest construction. As a safety factor the Handle Mechanism is built to specifications ten times the necessary strength to protect the Reel Mechanism from the most aggressive player.

There have been several new developments designed to strengthen and protect the Handle Mech. First an anti-fast pull Speed Lock (note ratchet) was added in 1970. In mid-1973 the Full Stroke Pawl & Locking Links were re-designed and strengthened.

You will notice that these improvements can be incorporated on

Older Machines. It is also suggested that the new front, Anti-Wiring Shield be in place at all times.

Because of the heavy duty use, the Handle Mech. should be lubricated periodically. Use our Lubriplate No. 1 Oil on the light

duty pivot points and our Hydro-tex Lube #651 on points of heavy stress and sliding parts.

Be sure the anti-fast pull, Speed Lock Pawl swings freely on its pivot, since it engages the Ratchet on a centrifugal force principle (do not lubricate).

MOLEX PLUG SERVICE

NOTE: The Molex Pin Extractor Tool enables easy service of the Molex Plug, Pins both male and female are removable. Holding Extractor Tool as shown in Illustration, placing Forefinger over shaft as to hold it from turning (as shown), push Shaft over Pin giving Tool a slight twist allowing the Pin Fins to compress easily, thus enabling the Pin to be pushed through Nylon Housing.

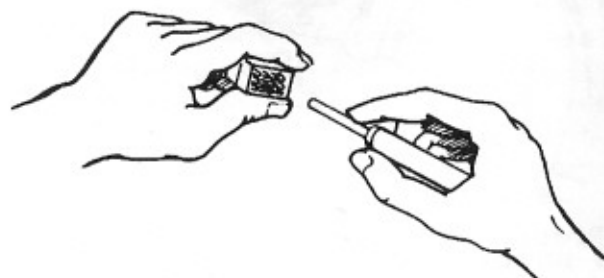

BALLY NO.	MOLEX NO.	TYPE
FEMALE E-663-2	02-09-1104	1190
FEMALE E-663-4	02-09-1119	1381
MALE E-661-2	02-09-2103	1189
MALE E-661-4	02-09-2118	1380

TYPE 1189-90 LONG EAR
 TYPE 1380-81 SHORT EAR
 HAND CRIMPING TOOL HT-1031

NOTE: REPLACEMENT ITEMS CAN BE ORDERED THRU BALLY DIST. OR NEAREST MOLEX REP. IN COUNTRY OF USE.

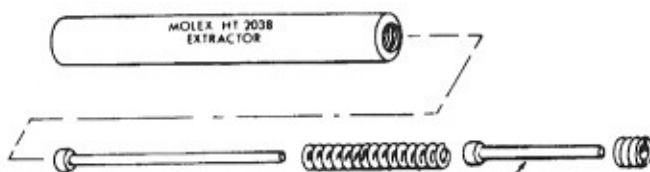
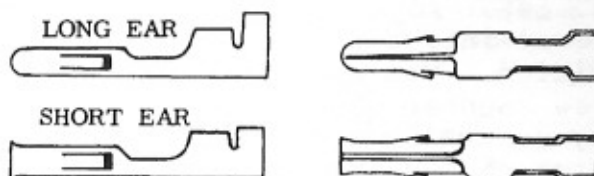
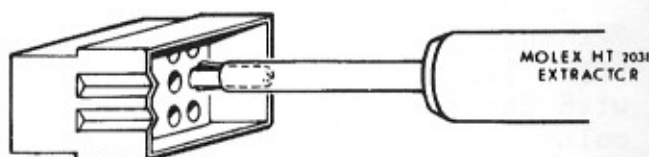

REPLACEMENT PART HT 1010-232

MOLEX PLUG RECEPTACLES

	MALE	FEMALE
2 PIN PLUG	660-2	662-2
4 PIN PLUG	660-4	662-4
12 PIN PLUG	660-12	662-12

STATE LAWS FOR POSSESSION OF SERIES E 1980-1986

January 1, 1995

Any Machine Legal: Alaska, Arizona, Arkansas, Kentucky, Maine, Minnesota, New Mexico, Nevada, Ohio, Texas, Utah, Virginia, West Virginia. **Pre-1984 Models:** Colorado

Machine Must be 20 Years or Older: Florida; **25 Years or Older:** California, Delaware, Illinois, Iowa, Louisiana, Maryland, Michigan, Mississippi, Montana, New Hampshire, North Carolina, North Dakota, Rhode Island, Oklahoma, Washington, Wyoming and Wisconsin.

30 Years or Older: Massachusetts, Missouri and New Jersey

(ownership is still illegal in the unlisted states, but check with a dealer, trade magazine or your state officials frequently as the laws are becoming more favorable)

HOT TIP

To purchase Bally SERIES E slots contact your local dealer, attend the antique coin shows and check the ads in the trade magazines and the classified section in newspapers. To verify the model of a machine with the year of manufacture refer to *Bally Slot Machines: An Illustrated Guide to the 114 Most Popular Ballys Made from 1964 -1987*. For ordering a copy of this book, see page 64 of this manual.

LUBRICATION GUIDE

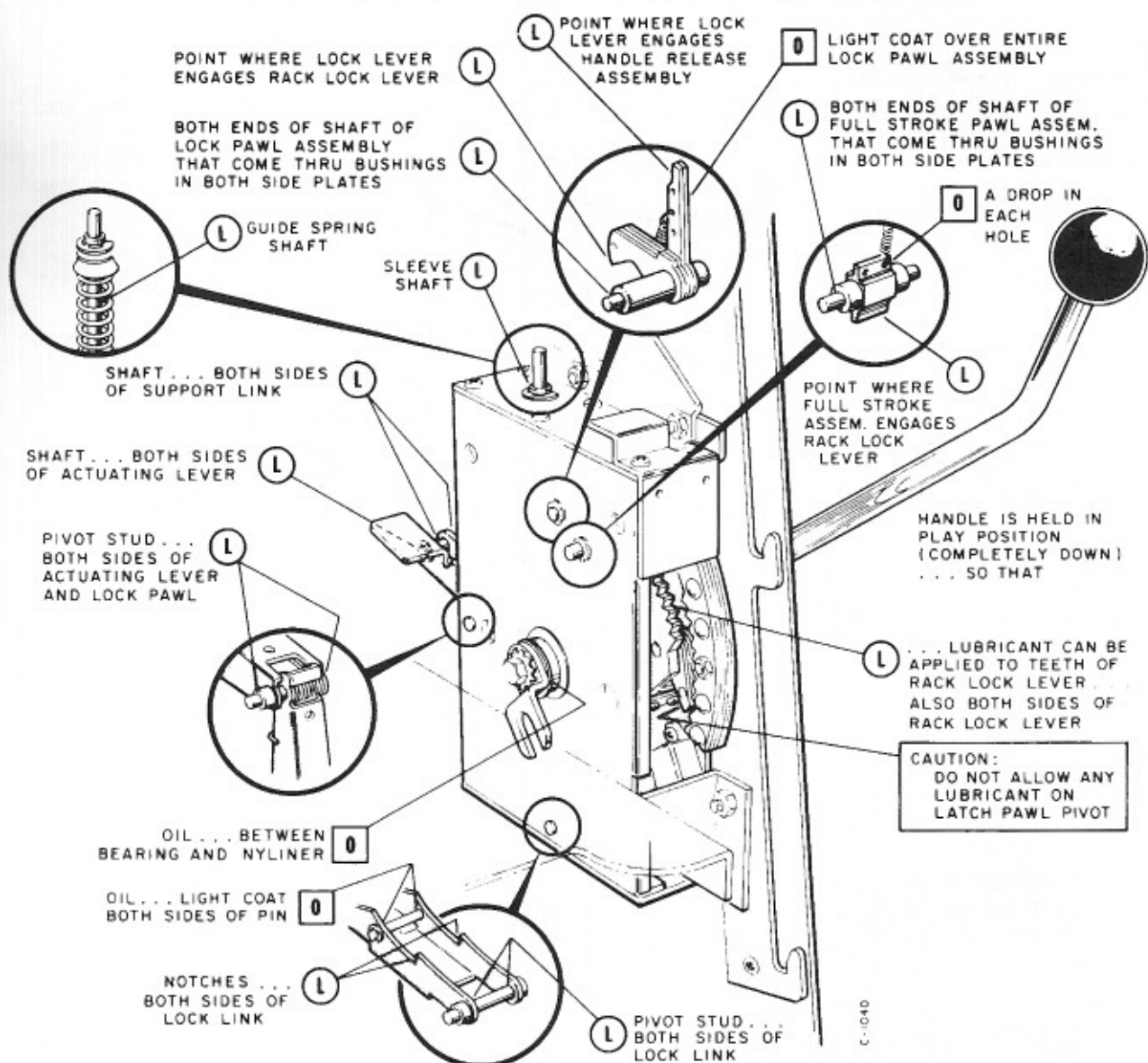

Figure 13. Handle Mechanism

BOTH ENDS OF PIN OF ROCKER AND ROLLER ASSEMBLY

OIL ... SHOULDER PIN OF ROCKER & ROLLER ASSEMBLY

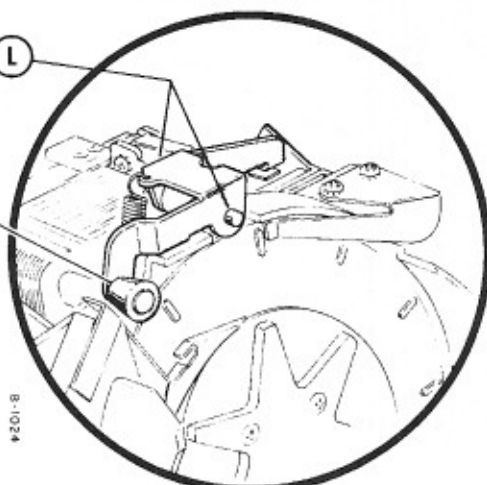

Figure 14. Hopper & Rocker Assembly

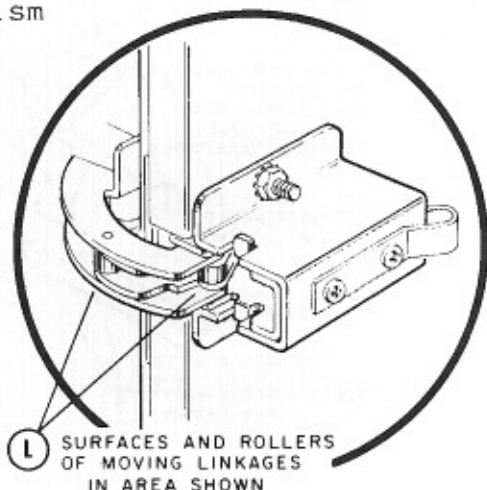

Figure 15. Front Door Hinge

LUBRICATION GUIDE

NOTE:

- (L)** INDICATES...USE HEAVY DUTY HYROTEX LUBE #651
- (O)** INDICATES...USE LUBRIPLATE #1 OIL (MARVEL MYSTERY OIL)

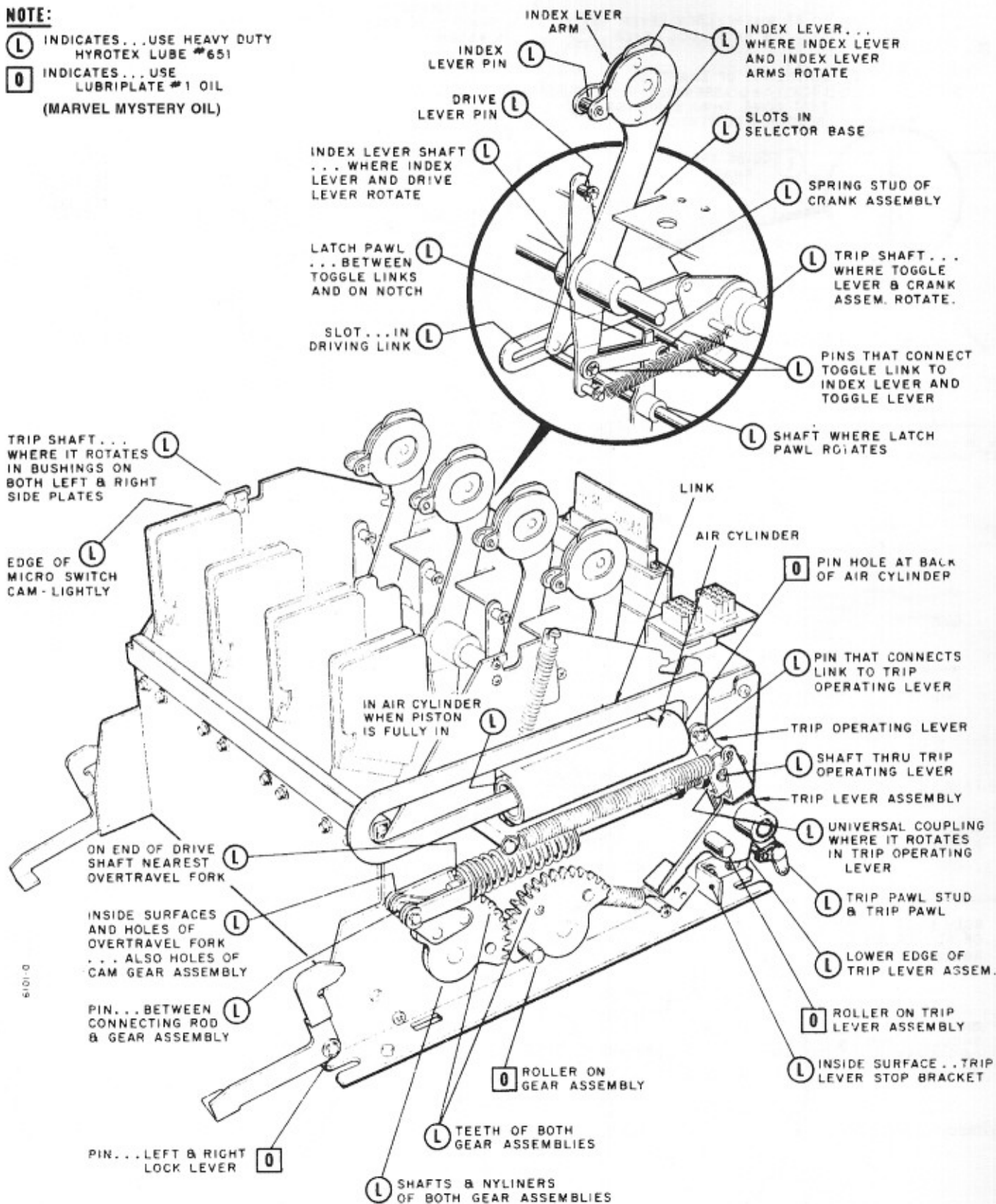

Figure 12. Reel Mechanism - (Soft Cushion)

LUBRICATION GUIDE

NOTE:

(L) INDICATES...USE HEAVY DUTY HYROTEX LUBE #651

(O) INDICATES...USE LUBRIPLATE #1 OIL (MARVEL MYSTERY OIL)

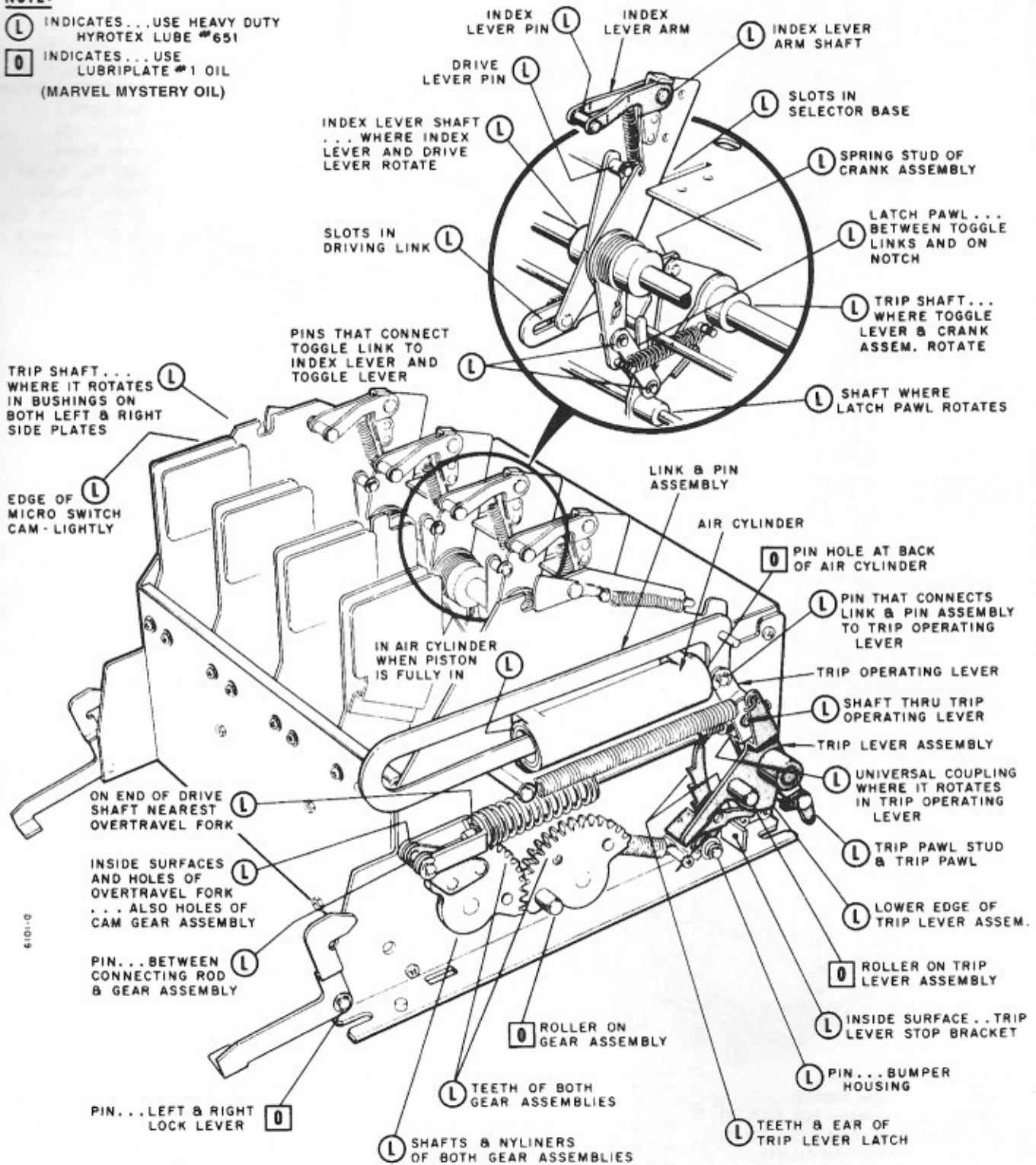
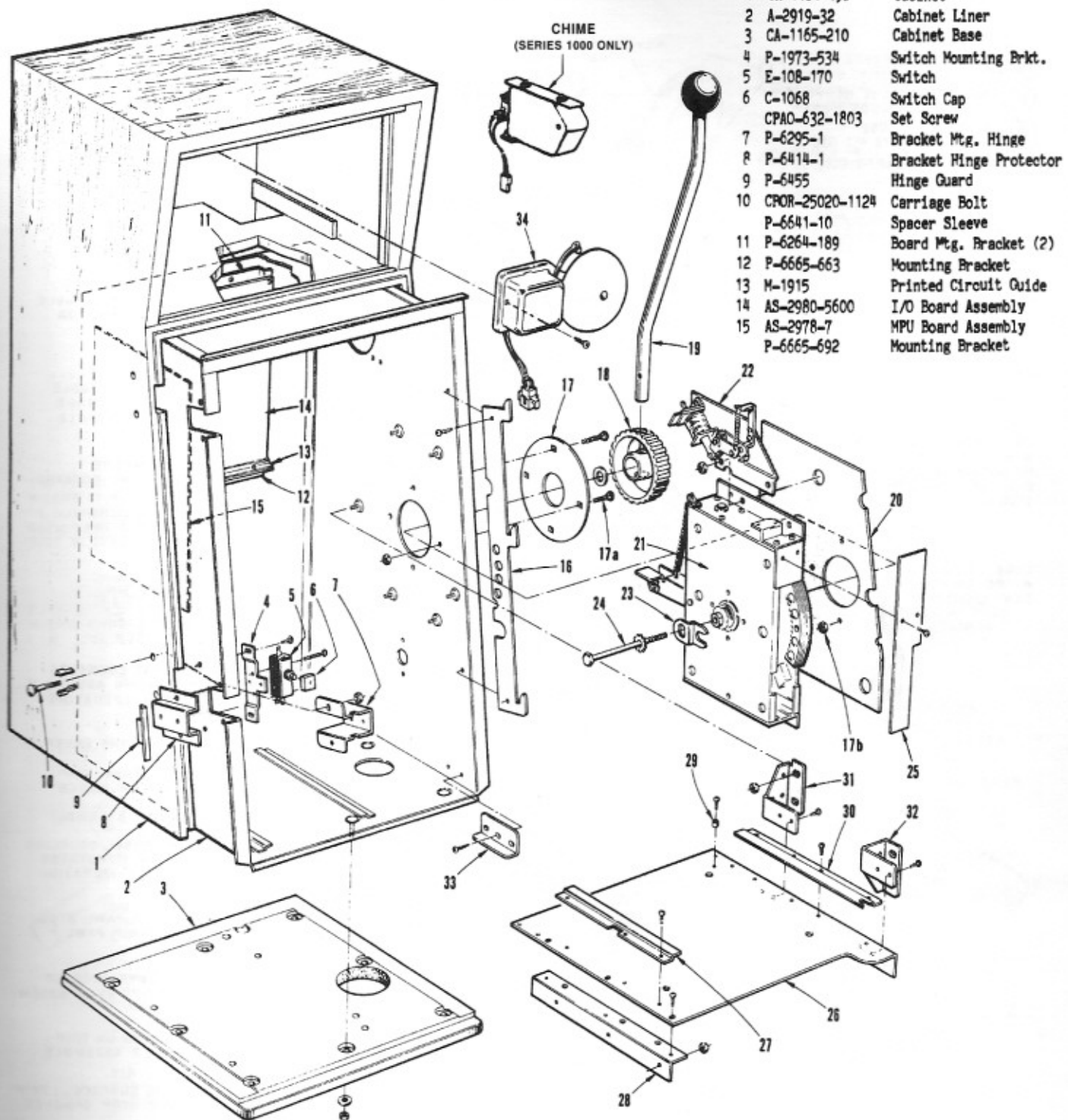

Figure 11. Reel Mechanism

CABINET ASSEMBLY - Part One



ITEM	PART NO.	DESCRIPTION
1	CA-1164-490	Cabinet
2	A-2919-32	Cabinet Liner
3	CA-1165-210	Cabinet Base
4	P-1973-534	Switch Mounting Brkt.
5	E-108-170	Switch
6	C-1068	Switch Cap
	CPAO-632-1803	Set Screw
7	P-6295-1	Bracket Mtg. Hinge
8	P-6414-1	Bracket Hinge Protector
9	P-6455	Hinge Guard
10	CPOR-25020-1124	Carriage Bolt
	P-6641-10	Spacer Sleeve
11	P-6264-189	Board Mtg. Bracket (2)
12	P-6665-663	Mounting Bracket
13	M-1915	Printed Circuit Guide
14	AS-2980-5600	I/O Board Assembly
15	AS-2978-7	MPU Board Assembly
	P-6665-692	Mounting Bracket

16	P-6416-1	Bar Lock	22	E-664-29	Molex Handle Lockout Assem.	30	P-6406-75	Rail Guide - Right
17	P-6280	Disc Mounting	23	P-6288	Actuating Arm		TFPP-1032-1806	Screw
	M-1348-1	Carriage Bolt 1-1/4 (3)	24	M-1372-10	Bolt	31	P-6268-4	Rail Mount Brkt. - Rear
17A	CPOR-25020-1118	Carriage Bolt 1-1/8 (1)		M-1702-23	5/16 Int-Ext Lockwasher	32	P-6268-3	Rail Mount Brkt. - Front
17B	M-1757-2	Nut - Special (1)	25	P-1973-319	Handle Mech. Cover	33	P-6665-337	Baffle (2)
18	C-641-31	Hub		RLPP-632-1804	Screw		SAPR-800-1110	Screw
	M-2020-1	Plug Button	26	P-511	Guide Rail Base Plate	34	E-664-19	Bell & Receptacle Assem.
	P-1158-6	Spring Washer		LSPR-1032-1104	Screw		M-1366	Bell
19	AS-2303	Handle Assembly	27	P-6406-74	Rail guide - Left		E-587-19	Diode
20	P-6281	Plate Mounting		RLPP-1032-1806	Screw		E-662-401	4 Pt. Molex Receptacle
21	AS-2301-11	Handle Mech. Assembly	28	P-6665-345	Guide Rail Mount Brkt.		E-663-1	Terminal
			29	S-231-794	Bushing		SAPR-800-1114	Screw

CABINET ASSEMBLY

Part Two

Note: On the Series 2000, the Fluorescent bulb in the Top Sign replaced the incandescent bulbs used on the previous models.

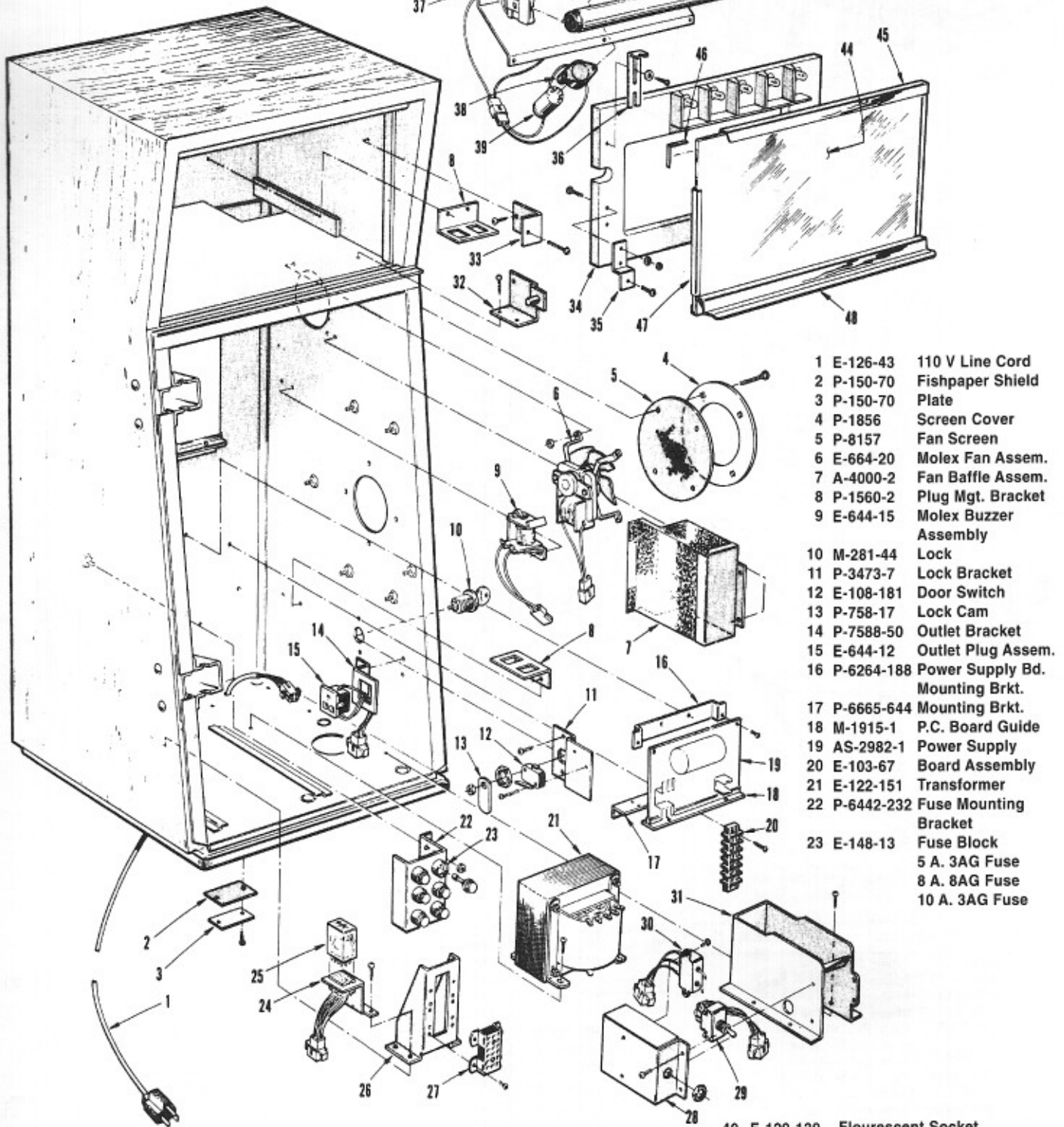

- 24 E-664-38 Molex Delay Relay Assem.
- 25 E-146-806 CR Relay (6VDC)
- 26 P-6417-3 Socket Mounting Plate
- 27 E-574-12 18 Pt. Socket
- 28 P-7990 Power Switch Cover
- 29 E-664-22 Power Switch Assembly
- 30 E-664-16 Molex Line Filter Assembly
- 31 A-3018-15 Coin Chue Assembly

- 32 A-1450-9 Insert Latch Assembly
- 33 P-6665-160 Insert Stop Bracket
- 34 A-3400-XXXX Insert & Lamp Socket Assem.
- 35 P-1820-2 Bracket
- 36 P-372-7 Bracket Insert Latch
- 37 P-8261-5 Light Reflector
- 38 E-120-120 Starter Socket
- 39 E-411-8 Fluorescent Starter

- 40 E-120-139 Fluorescent Socket
- 41 E-409-10 Ballast
- 42 R-111-8 Grommet
- 43 E-412-18 13W Fluorescent Lamp 12 In.
- 44 Feature Glass
- 45 P-6242-28 Glass Retainer - Upper
- 46 P-1925-211 Corner Bracket
- 47 P-6242-112 Glass Retainer - Side
- 48 P-6242-120 Glass Retainer - Lower

- 1 E-126-43 110 V Line Cord
- 2 P-150-70 Fishpaper Shield Plate
- 3 P-150-70 Plate
- 4 P-1856 Screen Cover
- 5 P-8157 Fan Screen
- 6 E-664-20 Molex Fan Assem.
- 7 A-4000-2 Fan Baffle Assem.
- 8 P-1560-2 Plug Mgt. Bracket
- 9 E-644-15 Molex Buzzer Assembly
- 10 M-281-44 Lock
- 11 P-3473-7 Lock Bracket
- 12 E-108-181 Door Switch
- 13 P-758-17 Lock Cam
- 14 P-7588-50 Outlet Bracket
- 15 E-644-12 Outlet Plug Assem.
- 16 P-6264-188 Power Supply Bd. Mounting Brkt.
- 17 P-6665-644 Mounting Brkt.
- 18 M-1915-1 P.C. Board Guide
- 19 AS-2982-1 Power Supply
- 20 E-103-67 Board Assembly
- 21 E-122-151 Transformer
- 22 P-6442-232 Fuse Mounting Bracket
- 23 E-148-13 Fuse Block
 - 5 A. 3AG Fuse
 - 8 A. 8AG Fuse
 - 10 A. 3AG Fuse

FRONT DOOR ASSEMBLY (Front View)

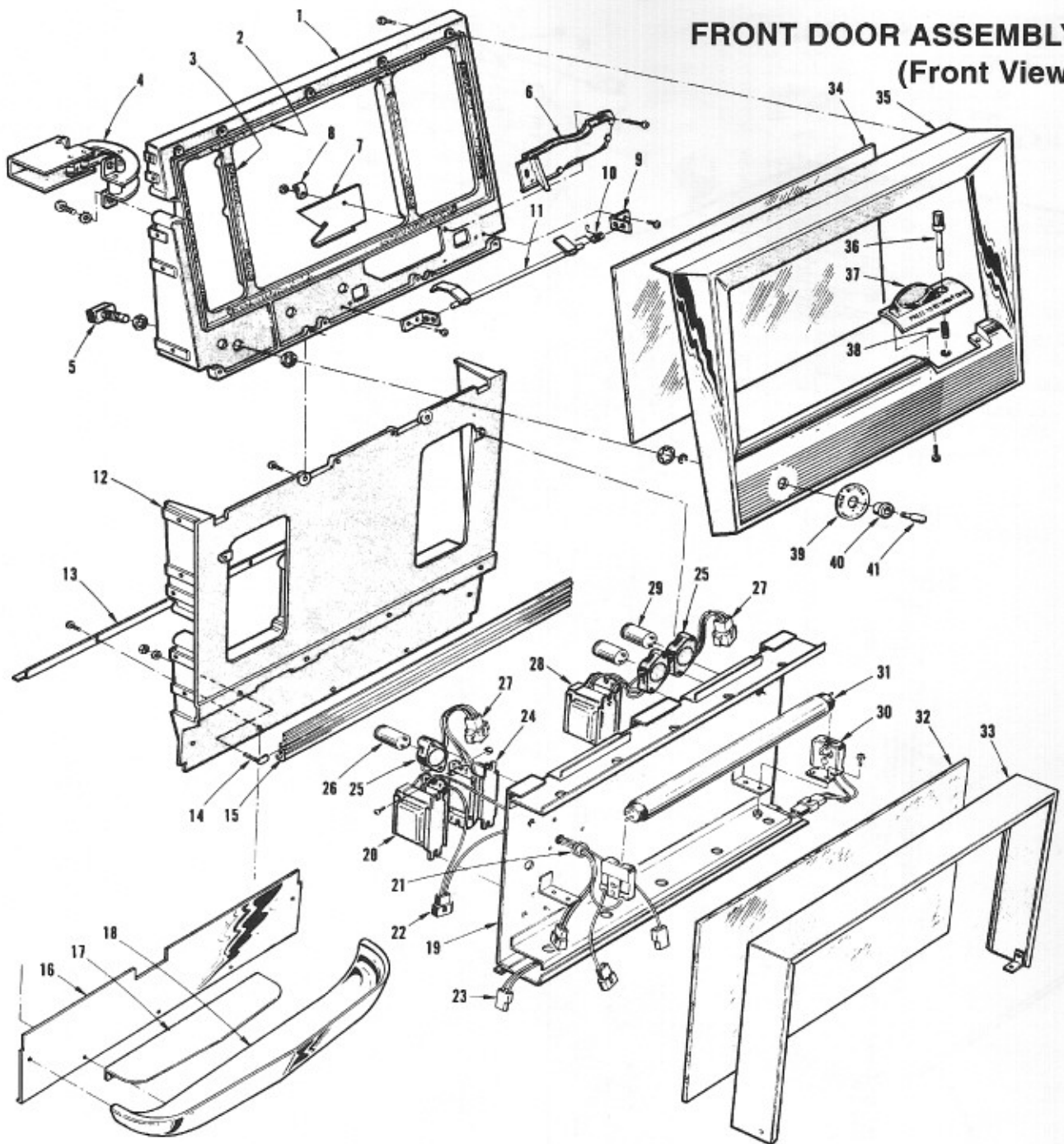

ITEM	PART NO.	DESCRIPTION
1	C-859	Upper Door Frame
2	R-380	Sponge Rubber - Seal
3	R-221-#3	Rubber Strip
4	A-2875-1	Hinge Assembly
5	E-108-97	Push Button Switch
6	AS-2342	Mechanical Rejector Uses: Coin Slide Assem. (5,10,25)
	AS-2342-1	Coin Slide Assembly (50)
	AS-2342-3	Coin Slide Assem. (5, 10, 25)
	AS-2342-N	Coin Slide Assembly (50)
7	P-7119-4	Coin Ramp Shield
8	C-271	Clip
	N-832-2112	Nut
9	P-6426	Scavenger Mtg. Bracket
10	SP-399-9	Torsion Spring
11	A-2929	Scavenger Assembly
12	C-854	Lower Door Frame (5,10,25)
	C-854-6	Lower Door Frame (50)
13	P-6665-75	Bottom Door Shield

14	M-606-29	Weld Screw
15	C-660-10	Extruded Trim (5,10,25)
	C-660-11	Extruded Trim (50)
16	P-6441	Trim Panel
17	P-7209	Coin Cup Guard Plate
18	C-655	Coin Cup
	LSPR-832-1108	Screw
19	A-3621-26	Glass Retainer Assembly
	R-221-32	Rubber Strip
	MSPB-832-1108	Screw
20	E-409-10	Ballast
21	R-111-8	Grommet
22	E-660-200	2 Pt. Molex Plug (4)
	E-661-1	Terminal
23	E-662-200	2 Pt. Receptacle (3)
	E-663-1	Terminal
24	E-409-14	Ballast (4 Watt)
	LSPR-632-1104	Screw
25	E-120-120	Starter Socket
	LSPR-632-110	Screw
26	E-411-8	Flourescent Starter

27	E-660-401	4 Pt. Molex Plug (2)
	E-661-1	Terminal
28	E-409-1	Ballast
29	E-411-7	Flourescent Starter (2)
30	E-120-139	Lampholder
31	E-412-18	Flourescent Lamp
32	G-350-XXX	Display Glass
33	A-3160-17	Retainer Frame Assem.
34	G-349-XXX	Reel Window Glass
35	C-658-3	Window Frame
36	A-3085	Scavenger Button Assem.
37	C-674	Coin Drop Casting (10¢)
	C-674-1	Coin Drop Casting (5¢)
	C-674-2	Coin Drop Casting (25¢)
	C-674-3	Coin Drop Casting (50¢)
38	SP-200-38	Compression Spring
	P-448-1	Snap Washer
39	M-1376	Push Button Disc
40	S-287-8	Button Housing
	P-3389-2	Retaining Ring
41	S-286-24	Push Button
	P-6316-6	Retaining Ring

FRONT DOOR ASSEMBLY (Rear View)

- 1 C-1154-1 Lower Door Frame
- 2 C-1159-1 Upper Door Frame
- 3 P-7120 Lock Side Protective Brkt.
- 4 P-6428-4 Guide Lock Slide
- 5 A-2928-1 Lock Slide Assembly
- 6 C-657-2 Door Frame - Right
- 7 M-281-40 Lock
- 8 E-108-183 Switch
- 9 A-2930-5 Lock Cam Assem.
- 10 P-816-14 Cam
- 11 P-6427 Lock Crank
- 12 A-2938-81 Light Brkt. Assem.
- 13 E-120-119 Lampholder

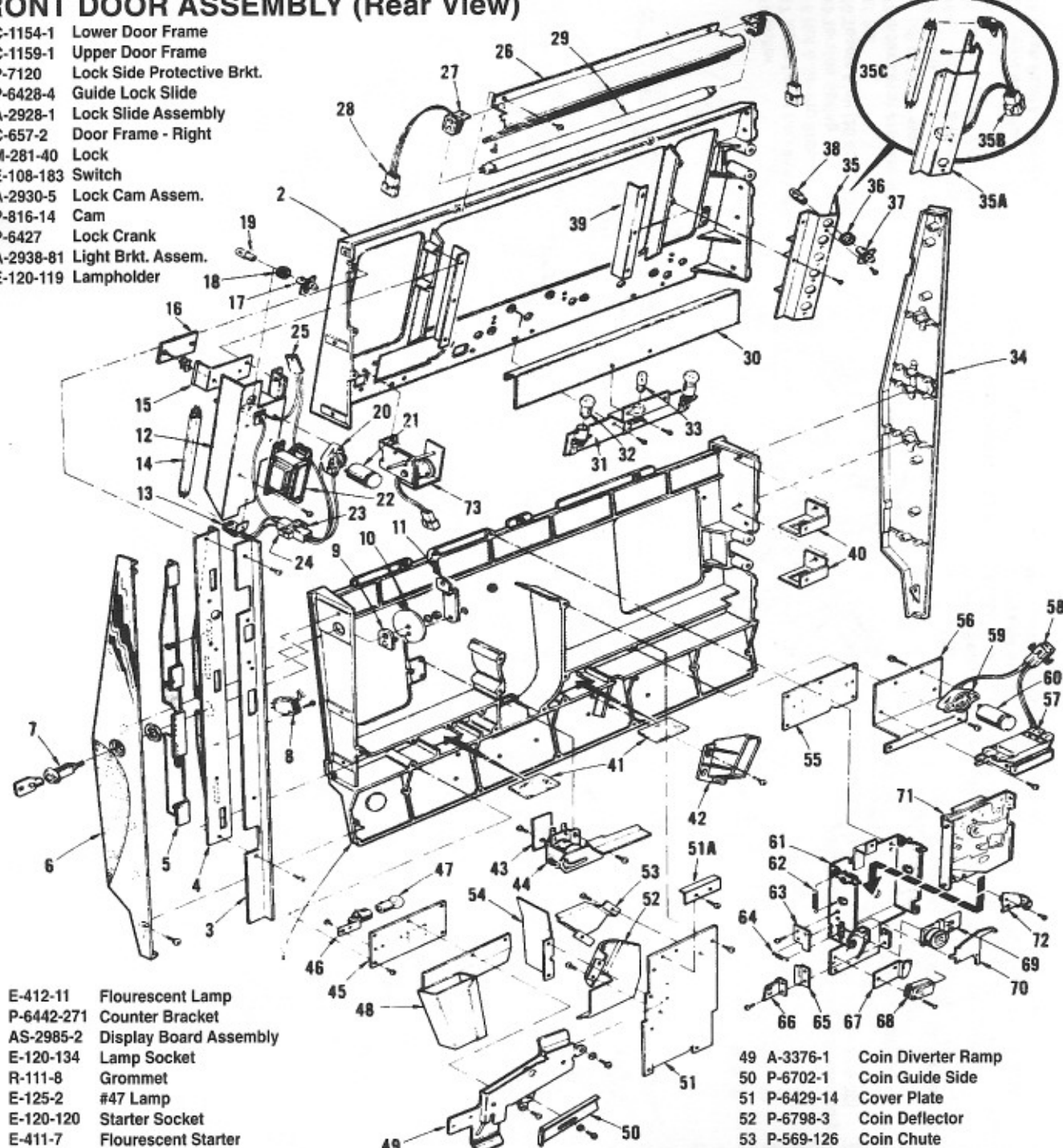

- 14 E-412-11 Fluorescent Lamp
- 15 P-6442-271 Counter Bracket
- 16 AS-2985-2 Display Board Assembly
- 17 E-120-134 Lamp Socket
- 18 R-111-8 Grommet
- 19 E-125-2 #47 Lamp
- 20 E-120-120 Starter Socket
- 21 E-411-7 Fluorescent Starter
- 22 E-409-1 Ballast
- 23 E-662-401 4 Pt. Molex Receptacle
- 24 E-660-401 4 Pt. Molex Plug
- 25 E-660-200 2 Pt. Molex Plug
- 26 P-7786-7 Reel Mask (22/25 Stop)
- 26 P-7786-6 Reel mask (20 Stop)
- 27 E-120-119 Lampholder
- 28 E-660-200 2 Pt. Molex Plug
- 29 E-412-5 Fluorescent Lamp
- 30 A-2937-31 Light Baffle Assembly (22/25 stop)
- 31 A-2937-34 Light Baffle Mounting Bracket
- 32 A-2937-25 #63 Lamp (2)
- 33 E-125-B #47 Lamp
- 34 E-125-2 Door Frame - Left
- 35 C-657-3 Shield Assembly (5-Line)
- 35A A-2938-65 Shield Assembly (3-Line)
- A-2938-84 Fluorescent Light Shield Assem.

- 35B E-664-71 Fluorescent Socket Assem.
- E-120-119 Lampholder
- 35C E-412-11 Fluorescent Lamp
- 36 R-111-8 Grommet
- 37 E-120-178 Lamp Socket
- 38 E-125-2 #47 Lamp
- 39 P-6665-744 Reflector
- 40 P-8118 Plug Mounting Bracket
- 41 G-348 Windows
- 42 C-1073 Coin Exit Ramp
- 43 P-150-100 Insulator
- 44 AS2517-9 Coin Deflector Assembly
- 45 A-2929 Mount Mtg. Plate Assem.
- 46 E-120-132 Lamp Socket
- 47 E-125-6 #63 Lamp
- 48 A-3018-72 Coin Slide Assembly

- 49 A-3376-1 Coin Diverter Ramp
- 50 P-6702-1 Coin Guide Side
- 51 P-6429-14 Cover Plate
- 52 P-6798-3 Coin Deflector
- 53 P-569-126 Coin Chute
- 54 P-569-125 Coin Baffle
- 55 A-2925-8 Light Mtg. Plate Assembly
- 56 AS-2335-13 Ballast Starter Assembly
- 57 SE-409-1 Ballast
- 58 E-660-401 4 Pt. Molex Plug
- 59 E-120-120 Starter Socket
- 60 E-411-4 Fluorescent Starter
- 61 A-1388-50 Rejector Mtg. Assembly
- 62 SP-148 Extension Spring
- 63 P-6692-1 Switch Mtg. Bracket
- 64 SP-199-16 Spring
- 65 P-6431-XX Coin Guide Spacer
- 66 P-6695 Coin Guide
- 67 P-6694 Coin Guide
- 68 AS-2744-19 Coin Switch & Wire Assem.
- 69 AS-2517-14 Coil Magnet Assembly
- 70 A-2958-XX Armature Assembly

3 REEL MECHANISM ASSEMBLY — Wide

- 1 Side Plate Assembly - Right
- 2 Tier Bar Bracket
- 3 Selector Base
- 4 Plug Mounting Bracket
- 5 Nyliner
- 6 Trip Shaft Assembly
(includes items 8, 9 & 10)
- 7 Bushing
- 8 Toggle Lever & Bushing Assembly
- 9 Crank Assembly
- 10 Bushing (2)
- 11 Toggle Lever & Link Assembly
- 12 Spring (3)
- 13 Index Lever Shaft
- 14 Index Lever Assembly
- 15 Index Lever Arm Assembly

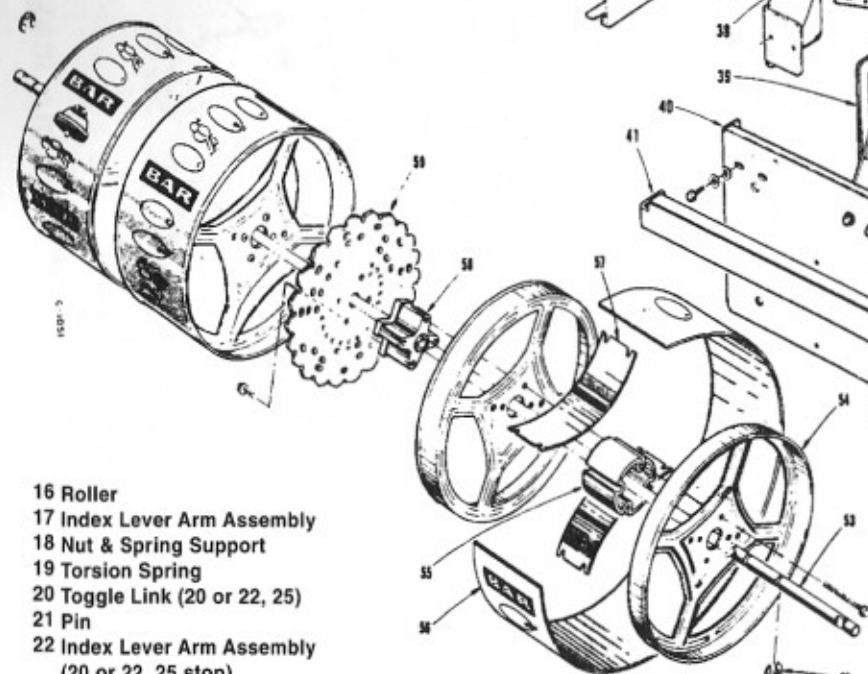

- 16 Roller
- 17 Index Lever Arm Assembly
- 18 Nut & Spring Support
- 19 Torsion Spring
- 20 Toggle Link (20 or 22, 25)
- 21 Pin
- 22 Index Lever Arm Assembly
(20 or 22, 25 stop)
- 23 Spring
- 24 Drive Lever & Roller Assembly
- 25 Bushing (part of item 24)
- 26 Nyliner
- 27 Toggle Stop Rod
- 28 Latch Pawl Assembly
- 29 Pin
- 30 Spring - Green (3)
- 31 Spring Rod
- 32 Side Plate Assembly - Left
- 33 Switch Bracket
- 34 Arm Switch

- 35 Kick Switch & Bracket Assembly
- 36 Cam & Hub Assembly
- 37 Reader Bracket Assembly Right
- 38 Illumination Bracket Assembly

- 39 Position Bracket Assembly
(includes items 37 & 38)
- 40 Front Plate
- 41 Front Plate Stiffener
- 42 Plastic Spacer
- 43 Reel Reader Control Board
- 44 Channel - Reel Support
- 45 Reel Shaft Support
- 46 Index Coil & Base Assembly
- 47 Plunger Guide Bracket
- 48 Snap-in-Liner

- 49 Plunger
- 50 Compression Spring
- 51 'J' Coil Assembly
- 52 Core Plug assembly
- 53 Reel shaft
- 54 Reel
- 55 Spacer (Wide)
- 56 Reel Tapes (20, 22, or 25 stop)
- 57 Reel Clamp (Wide)
- 58 Hub & Bearing Assembly
- 59 Index Disc (20, 22, or 25 stop)
- 60 Retaining Ring

- 49 Plunger
- 50 Compression Spring
- 51 'J' Coil Assembly
- 52 Core Plug assembly
- 53 Reel shaft
- 54 Reel
- 55 Spacer (Wide)
- 56 Reel Tapes (20, 22, or 25 stop)
- 57 Reel Clamp (Wide)
- 58 Hub & Bearing Assembly
- 59 Index Disc (20, 22, or 25 stop)
- 60 Retaining Ring

REEL MECHANISM ASSEMBLY

Right Side

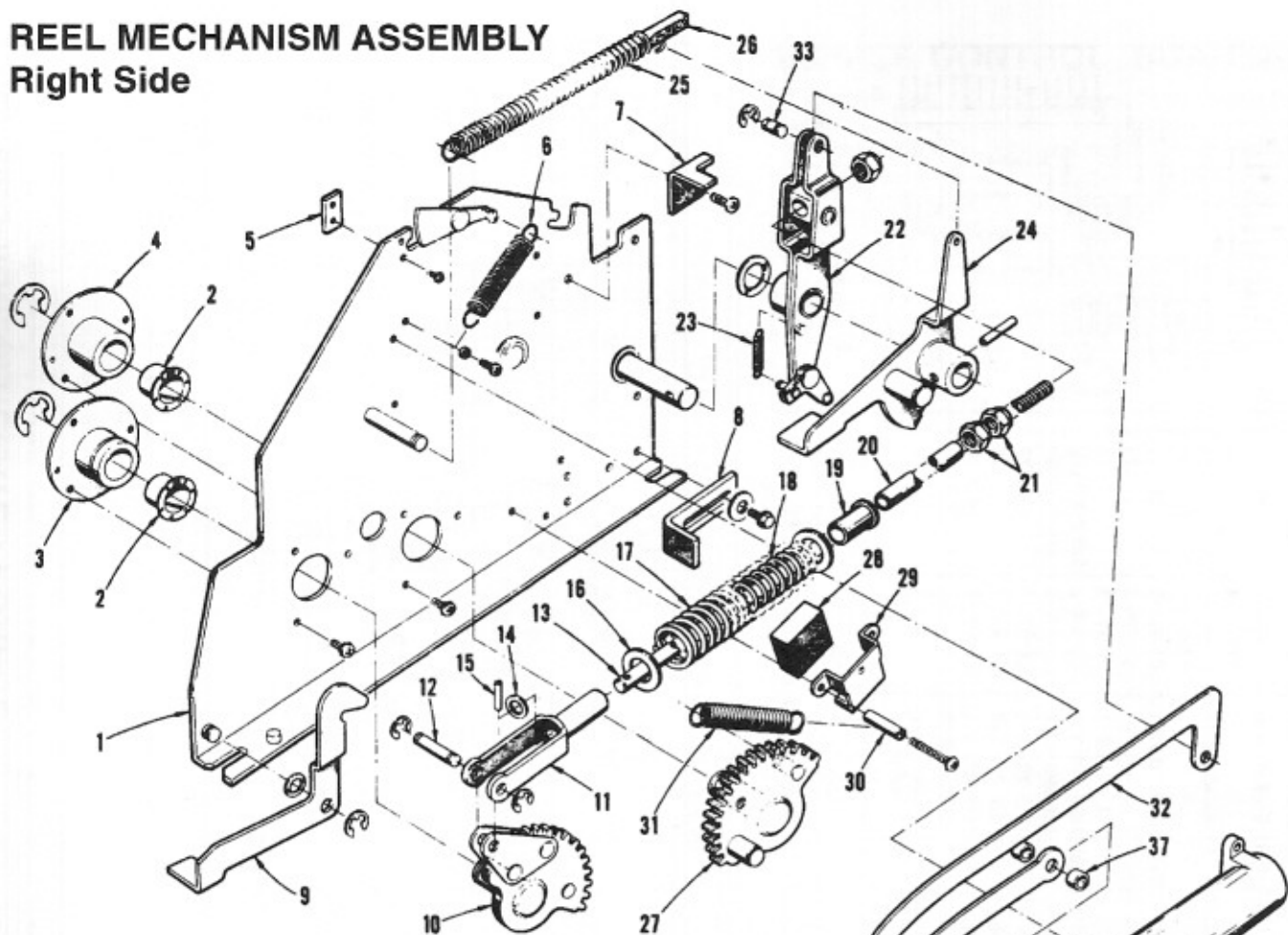

- | | | | | | | | | |
|----|-----------|-----------------------------|----|------------|-----------------------------|----|------------|------------------------|
| 1 | 2874-21 | Side Plate Assembly (Right) | 17 | SP-200-226 | Overload Spring (Outer) | 32 | P-645-1 | Link |
| 2 | C-537-31 | Nyliner | 18 | SP-200-225 | Overload Spring (Inner) | 33 | S-739-16-0 | Coupling Pin |
| 3 | A-2903 | Gear Plate Assembly | 19 | S-156-591 | Shoulder Bushing | 34 | S-369 | Piston |
| 4 | A-2903-2 | Gear Plate Assembly (Back) | 20 | S-231-911 | Bushing | 35 | R-1211 | Piston Cup Seal |
| 5 | P-126-541 | Plate | 21 | M-319-10 | Elastic Stop Nut | 36 | S-1071-83 | Rod (Air Cylinder) |
| 6 | SP-100-21 | Extension Spring | 22 | A-199-2 | Trip Operation Lever Assem. | 37 | S-231-41 | Bushing (Air Cylinder) |
| 7 | P-6451 | Stop Bracket | 23 | SP-100-12 | Extension Spring | 38 | C-112 | Cylinder |
| 8 | P-6287 | Bracket Stop | 24 | A-178-1 | Trip Lever Assembly | | | |
| 9 | P-6282-8 | Lock Lever (Right) | 25 | SP-100-241 | Extension Spring | | | |
| 10 | A-2865-1 | Gear Assembly | 26 | M-331-1 | Felt Plug | | | |
| 11 | A-171-1 | Over Travel Fork | 27 | A-2865 | Gear Assembly | | | |
| 12 | S-739-157 | Coupling Pin | 28 | R-116 | Bumper | | | |
| 13 | S-2033-1 | Drive Shaft | 29 | P-474 | Bumper Housing | | | |
| 14 | P-800-2 | Washer | 30 | M-1481-27 | Split Spacer | | | |
| 15 | P-1637-11 | Rail Pin | 31 | SP-100-312 | Extension Spring | | | |
| 16 | P-801-21 | Washer (2) | | | | | | |

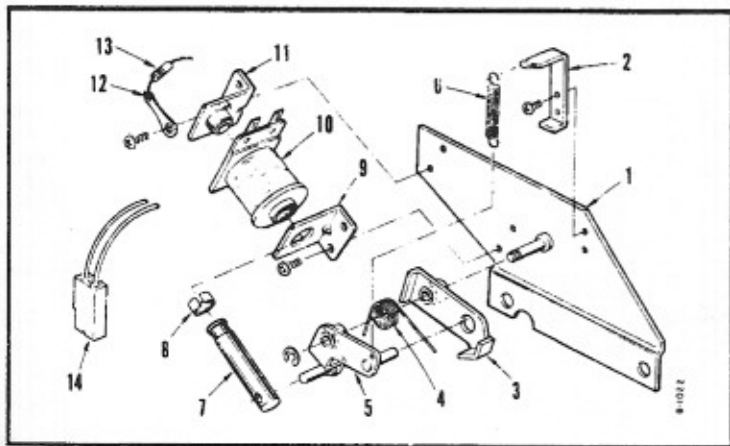

HANDLE LOCKOUT ASSEMBLY

- | | | |
|----|------------|---------------------------------|
| 1 | A-636-22 | Lockout Mounting Plate Assembly |
| 2 | P-454-59 | Spring Hook Bracket |
| 3 | A-3990 | Release Pawl Assem. |
| 4 | SP-399-43 | Torsion Spring |
| 5 | A-3989 | Plunger Stop Link Assembly |
| | P-6316-4 | Retaining Ring |
| 6 | SP-100-334 | Extension Spring |
| 7 | S-496-230 | Plunger |
| 8 | C-342 | Guide Ring-Nylon |
| 9 | P-108-53 | Coil Bracket |
| 10 | C-31-2600 | Coil |
| 11 | A-613-33 | Core Plug & Bracket Assembly |
| 12 | E-405-14 | Terminal |
| 13 | E-105-300 | 2.7K, 2W. Resistor |
| 14 | E-662-200 | 2 Pt. Molex Receptacle |

REEL MECHANISM RELATED BOARDS

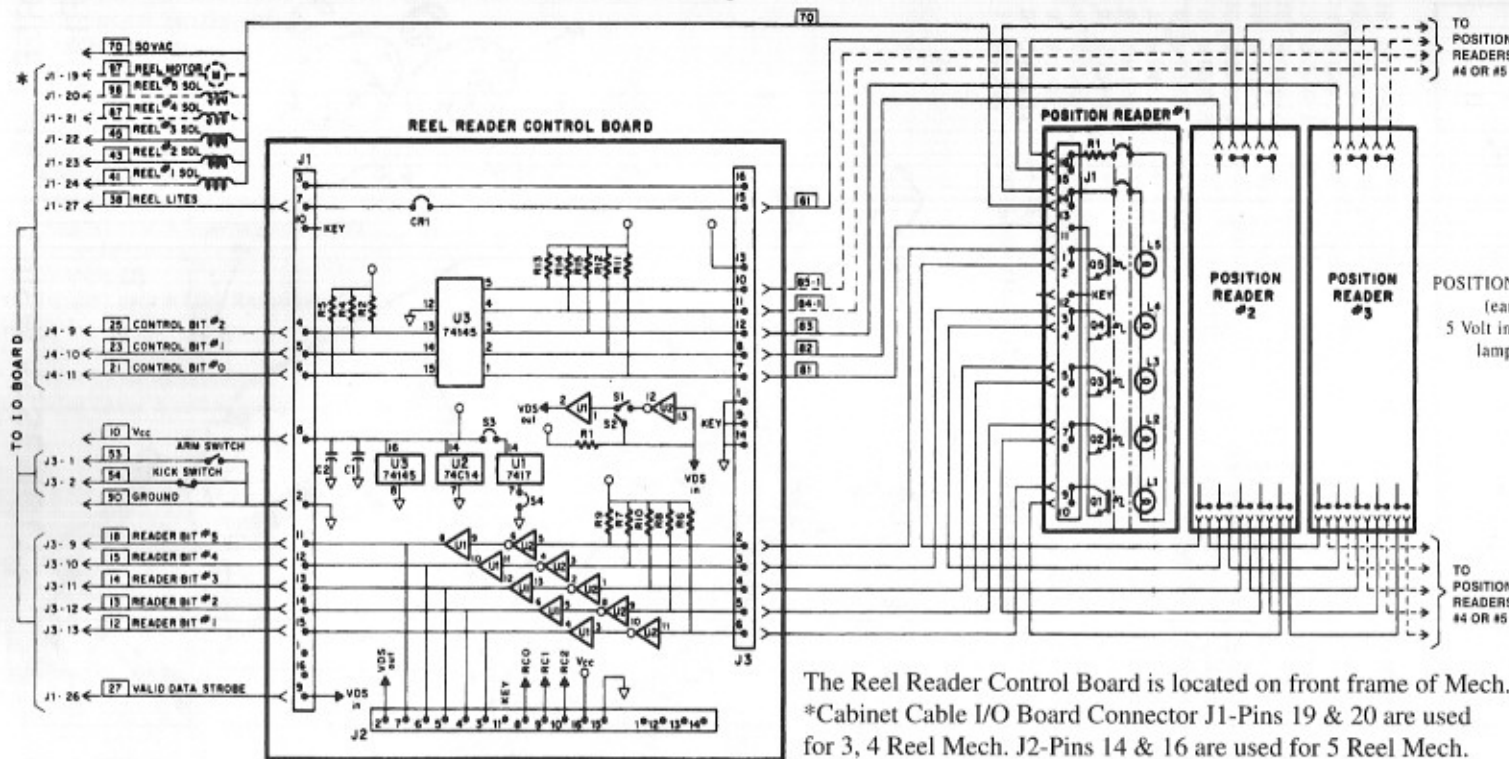

The Reel Reader Control Board is located on front frame of Mech.
 *Cabinet Cable I/O Board Connector J1-Pins 19 & 20 are used for 3, 4 Reel Mech. J2-Pins 14 & 16 are used for 5 Reel Mech.

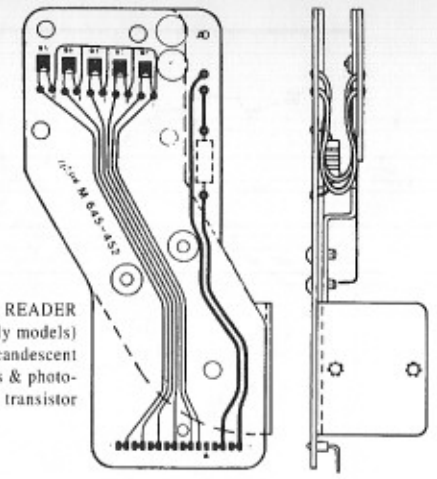

AS-2977-1 POSITION READER ASSEMBLY		
SYMBOL	PART NO.	DESCRIPTION
	A-3933-2	LAMP BRACKET ASSEMBLY
	A-3933-3	READER BRACKET ASSEMBLY
L1 - L5	E-125-88	5 VOLT LAMP
Q1 - Q5	E-585-55	NPN PHOTOTRANSISTOR
R1	E-104-101	470 OHM 2 WATT RESISTOR
J1	E-768-16	16 CKT. KK100 RIGHT ANGLE WAFER

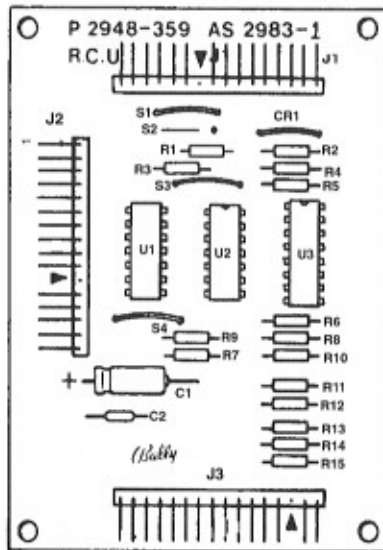

AS-2983-1 REEL READER CONTROL BOARD ASSEMBLY		
SYMBOL	PART NO.	DESCRIPTION
U1	E-820-85	7417 HEX BUFFER/D.C.
U2	E-820-78	74C14 HEX SCHMITT IND
U3	E-820-63	74145 BCD/DEC. DECODER
CR1	—	WIRE JUMPER
R1 - R2	E-105-230	1 K OHM RESISTOR 1/4 WATT 5%
R3	E-105-280	470 OHM RESISTOR 1/4 WATT 5%
R4 - R5	E-105-230	1 K OHM RESISTOR 1/4 WATT 5%
R6 THRU R10	E-105-283	47 K OHM RESISTOR 1/4 WATT 5%
R11 THRU R15	E-105-230	1 K OHM RESISTOR 1/4 WATT 5%
C1	E-588-8	2 MFD 50 V. ELECTROLYTIC
C2	E-586-85	.01 MFD 50 V. CERAMIC
J1, J3	E-768-16	16 CKT. KK100 RIGHT ANGLE WAFER
J2	NOT USED	
S1	—	WIRE JUMPER IN CIRCUIT
S2	NOT USED	
S3, S4	—	WIRE JUMPER IN CIRCUIT

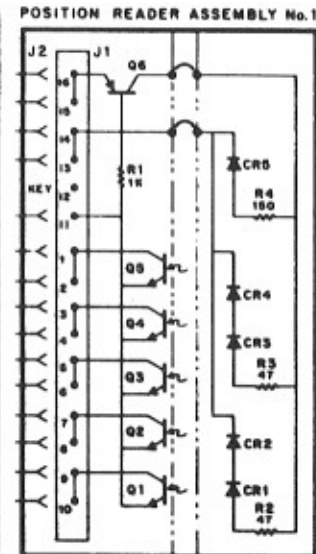

AS-2977-6 POSITION READER ASSEMBLY		
SYMBOL	PART NO.	DESCRIPTION
	A-3933-6	Illum. Bracket Assembly
	A-3933-7	Reader Bracket Assembly
CR1 thru CR5	E-679-9	Infra-red LED (5)
Q1 thru Q5	E-585-86	NPN Phototransistor
J1	E-768-16	16 Ckt. KK100 Rt. Angle Wafer
R4	E-105-233	150 Ohm Resistor
R1	E-105-230	1K Ohm Resistor
R2, R3	E-105-322	47 Ohm Resistor (2)
Q6	E-585-4	MPS6517 PNP Transistor

On the early models, above, the paylines on each reel are read by a 5-volt lamp that actuates a photo-transistor, Q1-Q5, sending a signal to the reel reader board. On the later models the CR1-CR5 on the Position Reader, left, are the Infra-Red LED source for Q1-Q5 Phototransistors.

HOPPER CONTROL BOARDS

The board controls the Hopper Motor which dispenses coins, calculates the coins paid out via the Opto Switch (p. 33) and maintains the coin level by means of the Coin Level Switch (P.35). Located at the front of the Hopper, it contains both the Test & Reset Switches (p. 7).

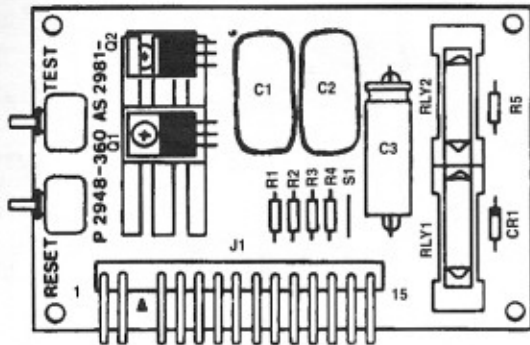
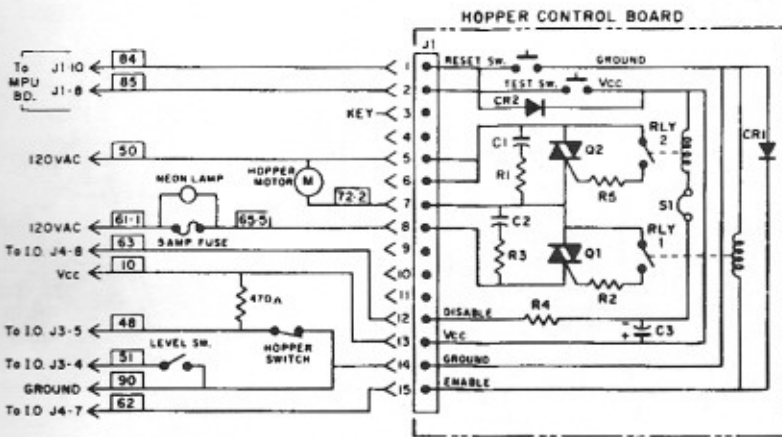

1000 Series

AS-2981-1 HOPPER CONTROL BOARD ASSEMBLY		
SYMBOL	PART NO.	DESCRIPTION
Q1	E-585-54	MAC15-6 Triac
	E-682-10	Heat-Sink - Thermalloy '6070'
	LSPR-632-1104	Screw
	M-1700-6	Lockwasher
	N-632-2112	Nut
Q2	E-585-54	MAC15-6 Triac
	LSPR-632-1104	Screw
	M-1700-6	washer
	N-632-2112	Nut
	C1	E-586-200
C2	E-586-200	.22MFD. 400V. Metalized Film
C3	E-586-106	200 MFD. 16. Electrolytic
CR1	E-587-14	1N4148 Diode
CR2	E-587-6	1N4004 Diode (located on back)
R1	E-105-306	10 Ohm. Resistor 1/4 Watt 5%
R2	E-105-280	470 Ohm. Resistor 1/4 Watt 5%
R3	E-105-306	10 Ohm. 1/4 Watt 5%
R4	E-105-301	100 Ohm. Resistor 1/4 Watt 5%
R5	E-105-280	470 Ohm. Resistor 1/4 Watt 5%
RLY1-RLY2	E-146-796	Electro RA31441051 Reed Relay
Reset Sw.	E-658-1	P.B. P.C. Mount Switch
Test Sw.	E-658-1	P.B. P.C. Mount Switch
S1	Wire Jumper	Wire Jumper
J1	E-758-15	15 Ckt. KK Right Angle Wafer

AS-2981-4 HOPPER CONTROL BOARD ASSEMBLY

SYMBOL	PART NO.	DESCRIPTION	SYMBOL	PART NO.	DESCRIPTION	SYMBOL	PART NO.	DESCRIPTION
U1, U3, U4	E-620-243	MOC119 Opto Coupler	CR13	E-679-1	Red Led	R15, R21,	E-105-230	1K Ohm 1/4W 5% Resistor
U2	E-620-172	Optically Isolated Optical Driver	C1, C7	E-586-207	.22MFD 400V Polyester Capacitor	R22	E-105-230	1K Ohm 1/4W 5% Resistor
U3	E-681	3081 NPN Transistor Array	C2,	E-586-211	10MFD 16V Tantalum Capacitor	R12	E-105-265	100 Ohm 1/2W 5% Resistor
Q1, Q2	E-585-76	S4015L 15A 400V. SCR	C3, C5	E-586-202	47MFD 25V Tantalum Capacitor	R16	E-105-281	15K Ohm 1/4W 5% Resistor
Q3	E-585-54	MAC15-6 15A 400V. Triac	C4, C6	E-586-85	.01MFD 25V Ceramic Capacitor	R20	E-105-134	51 Ohm 1/4W 5% Resistor
Q1 thru Q3	M-496-1	Push Rivet Stud	C8	E-586-209	1. MFD 400V Polyester Capacitor	R24	E-105-306	10 Ohm 1/4W 5% Resistor
CR1 thru CR4	E-587-14	1N4148 Diode	C9, C10	E-586-283	.1 MFD 50V Ceramic Capacitor	TEST	E-658-1	P. C. Mount Switch
CR5	E-587	1N 270 Diode	R1	E-105-76	12K Ohm 2W 10% Resistor	RESET	E-658-1	P. C. Mount Switch
CR6	E-598-20	Z3.6C20MA Zener Diode	R2, R7, R9, R11	E-105-235	180 Ohm 1/4W 5% Resistor	J1	E-758-15	15 Ckt. KK158 Rt. Angle Wafer
CR7, CR9	E-587-6	1N4004 Diode	R13, R14, R17	E-105-235	180 Ohm 1/4W 5% Resistor	J2	E-768-10	10 Ckt. KK 158 Rt. Angle Wafer
CR8, CR10	E-598-28	1N5242A ZENOR Diode	R3, R5, R18	E-105-264	270 Ohm 1/4W 5% Resistor	S1		Jumper Wire
CR11, CR12	E-587-25	1N5626 Diode	R4, R6, R8, R10	E-105-230	1K Ohm 1/4W 5% Resistor			

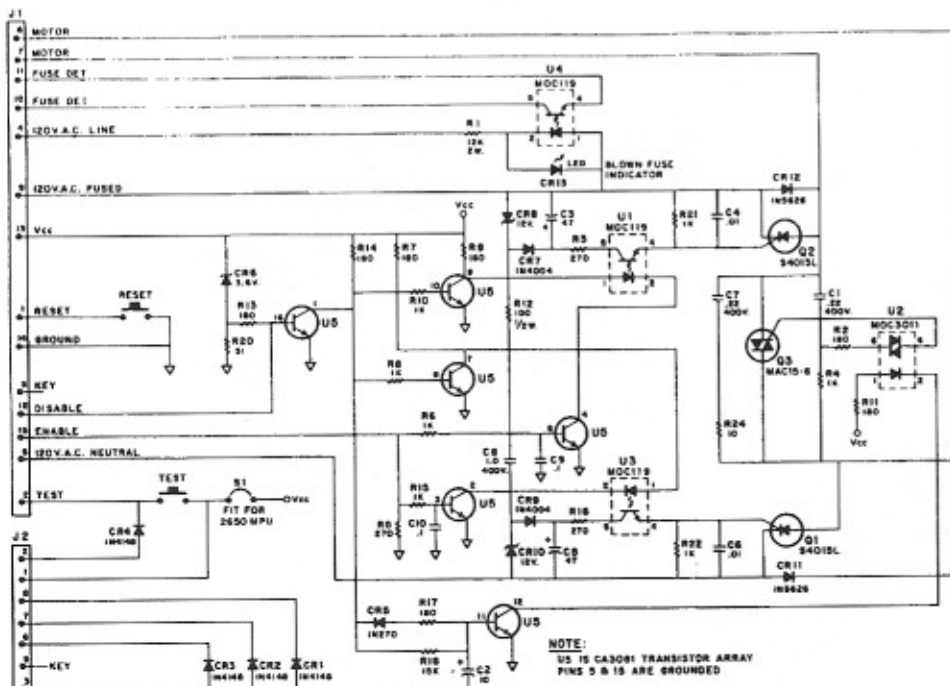

2000 Series

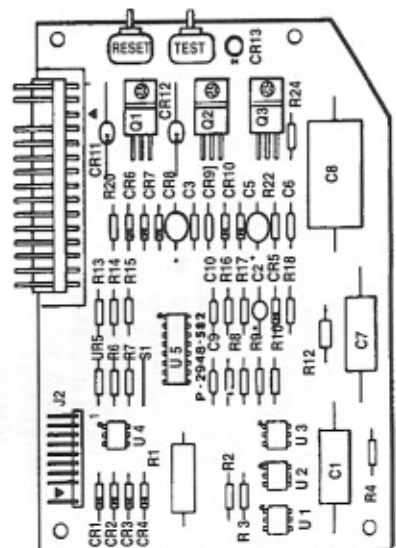

HOPPER PAYOUT UNIT ASSEMBLY

Motor (5-10-25-50)

Motor (Dollar)

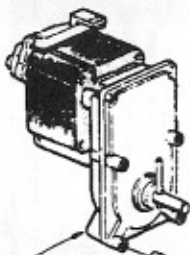
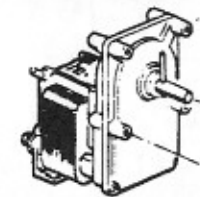

HOPPER STOP

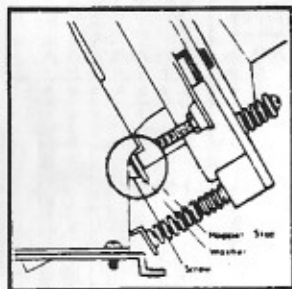

P-801-353

Washer
Screw

LSPR-1032-1106

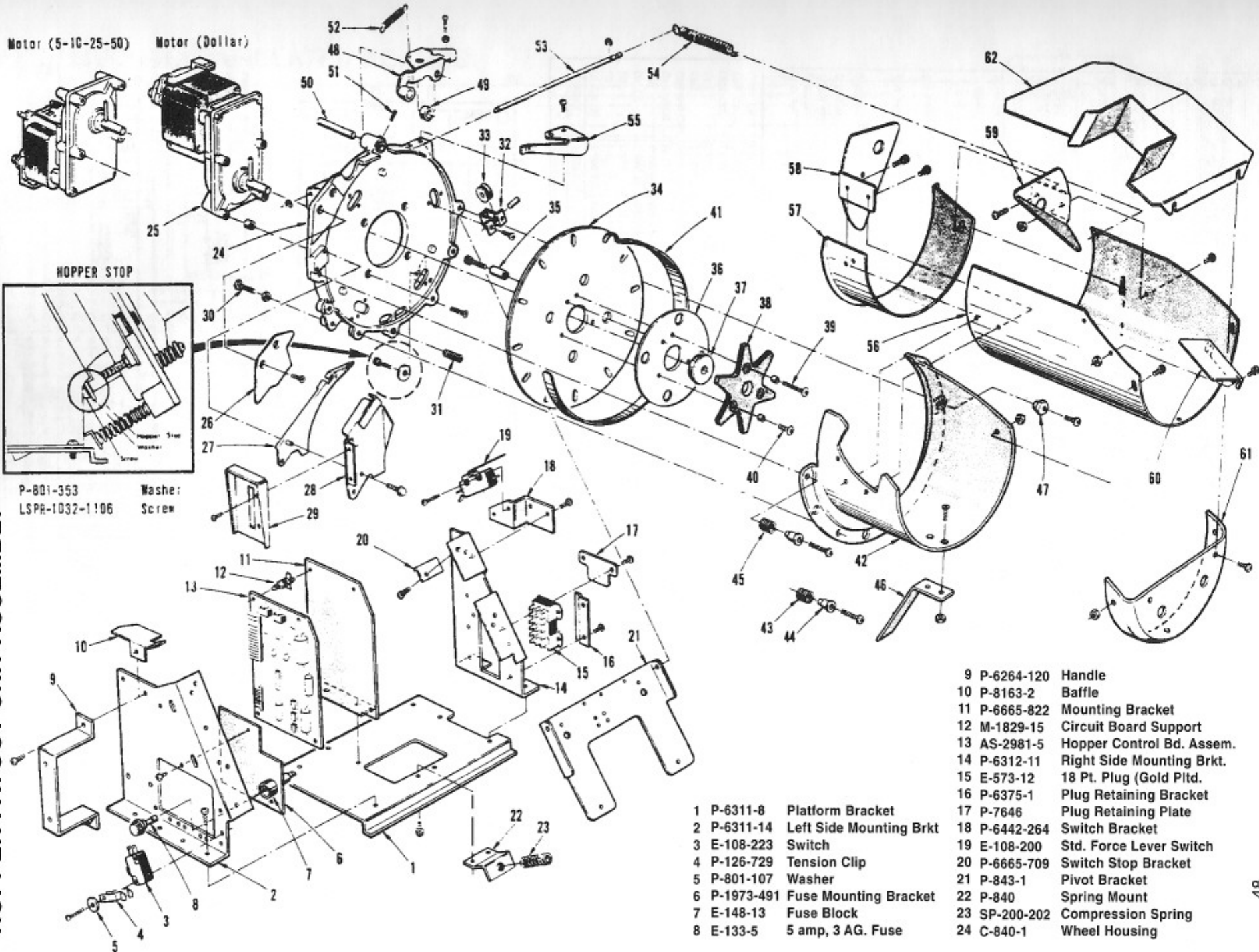

- 1 P-6311-8 Platform Bracket
- 2 P-6311-14 Left Side Mounting Brkt
- 3 E-108-223 Switch
- 4 P-126-729 Tension Clip
- 5 P-801-107 Washer
- 6 P-1973-491 Fuse Mounting Bracket
- 7 E-148-13 Fuse Block
- 8 E-133-5 5 amp, 3 AG. Fuse

- 9 P-6264-120 Handle
- 10 P-8163-2 Baffle
- 11 P-6665-822 Mounting Bracket
- 12 M-1829-15 Circuit Board Support
- 13 AS-2981-5 Hopper Control Bd. Assem.
- 14 P-6312-11 Right Side Mounting Brkt.
- 15 E-573-12 18 Pt. Plug (Gold Pltd.)
- 16 P-6375-1 Plug Retaining Bracket
- 17 P-7646 Plug Retaining Plate
- 18 P-6442-264 Switch Bracket
- 19 E-108-200 Std. Force Lever Switch
- 20 P-6665-709 Switch Stop Bracket
- 21 P-843-1 Pivot Bracket
- 22 P-840 Spring Mount
- 23 SP-200-202 Compression Spring
- 24 C-840-1 Wheel Housing

HOPPER PAYOUT UNIT ASSEMBLY

25 E-199-472	Motor	38 R-526	Agitator	51 M-1715-1	Nylok Set Screw
26 P-839	Coin Deflector	39 S-231-825	Screw & Bushing	52 SP-100-326	Extension Spring
27 P-846	Knife	40 MSPT-1032	Screw & Bushing	53 S-2018	Pivot Rod
28 A-3795-3	Outlet Cover Assembly	41 P-8195	Spring Liner	P-2891-5	Retaining Ring
29 P-7947	Hopper Baffle	42 C-841-3	Hopper Casting	54 SP-100-327	Extension Spring
30 M-1773	Screw	43 SP-200-191	Compression Spring (2)	55 P-845	Wiper
31 M-1590-1	Set Screw (Hopper Adj.)	44 S-2019	Mount	56 P-2495	Scoop Extension
32 P-6264-208	Bearing Bracket (4)	45 SP-200-203	Compression Spring	57 P-834	Hopper Liner
33 M-1689-1	Bearing (4)	46 P-2452	Scoop Support Leg	58 P-2540-4	Coin Baffle
34 P-842-XX	Pin Wheel (5-10, 25-50 & Dollar)	47 S-2119-1	Eccentric Mount	59 P-2540-5	Coin Baffle
35 S-231-826	Drive Bushing	48 A-2893-6	Rocker & Roller Assembly	60 P-6717-34	Inlet Slide
36 P-847-XX	Shelf Wheel (5, 10, 25, 50, Dollar)	49 S-231-914	Spacer	61 C-841-4	End cap Casting
37 S-2200	Pilot Bushing	50 S-1071-195	Dowel Pin	62 A-2940-5	Scoop Cover Assem.

HANDLE MECHANISM ASSEMBLY

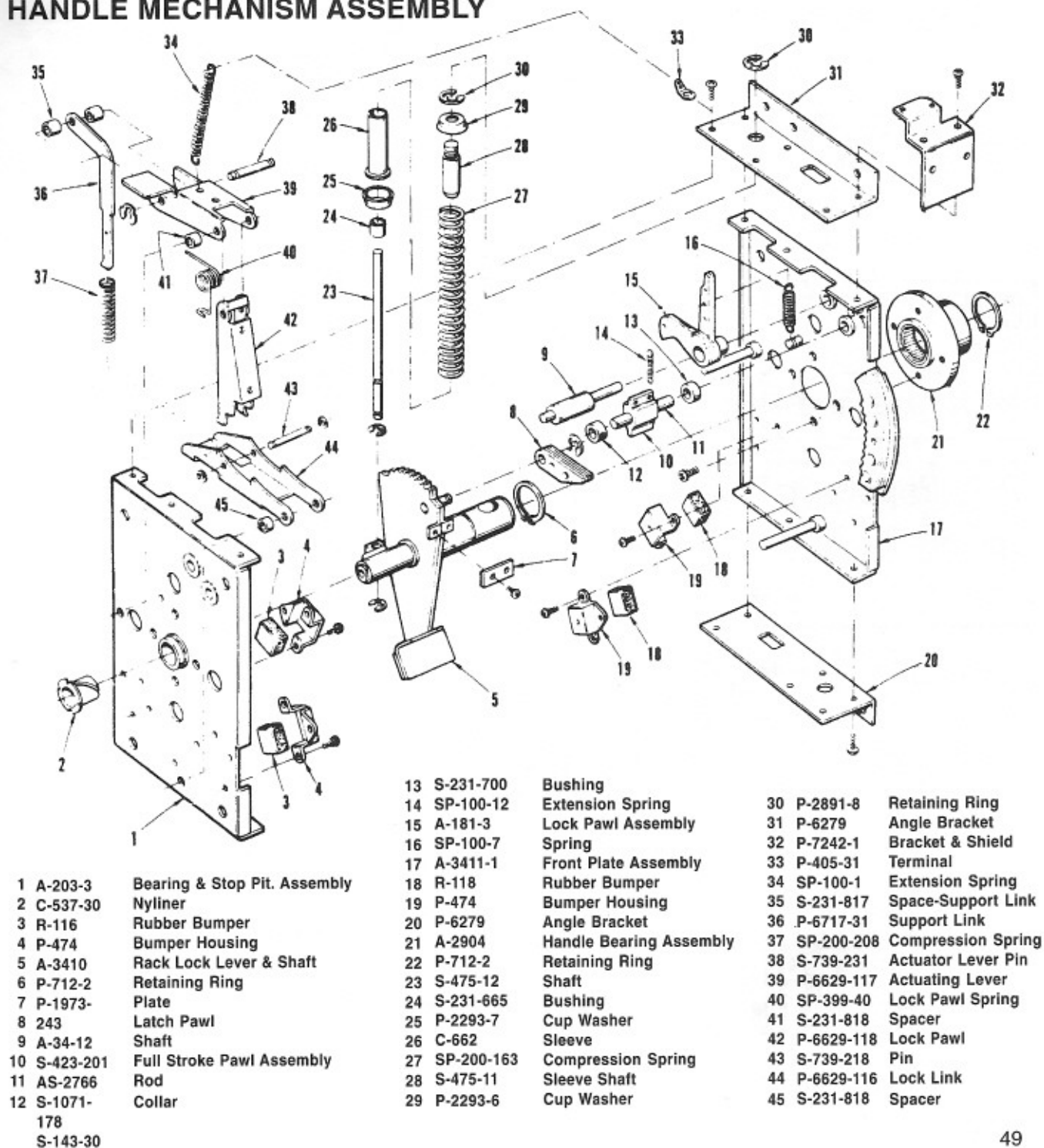

GAME POWER DISTRIBUTION

110 V.A.C. & MAIN TRANSFORMER POWER DISTRIBUTION

WIRING COLOR CODE	
1	RED
2	BLUE
3	YELLOW
4	GREEN
5	WHITE
6	BROWN
7	ORANGE
8	BLACK
9	GRAY
0	NO TRACER
J	JUMPER
EXPLANATION OF NUMBERS CHART P. 53	

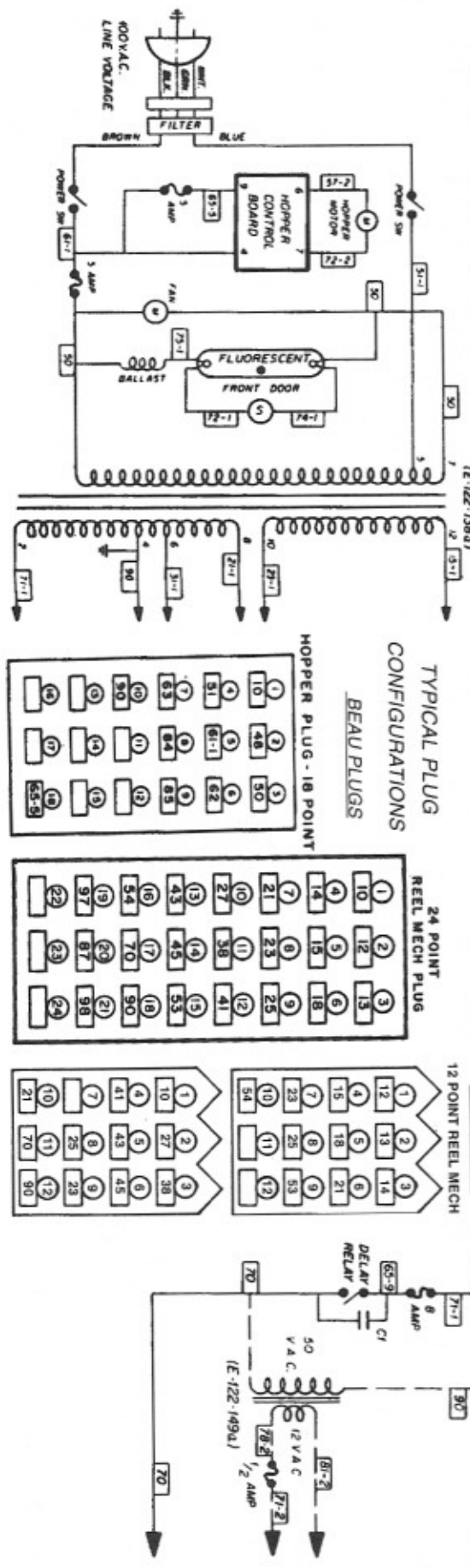
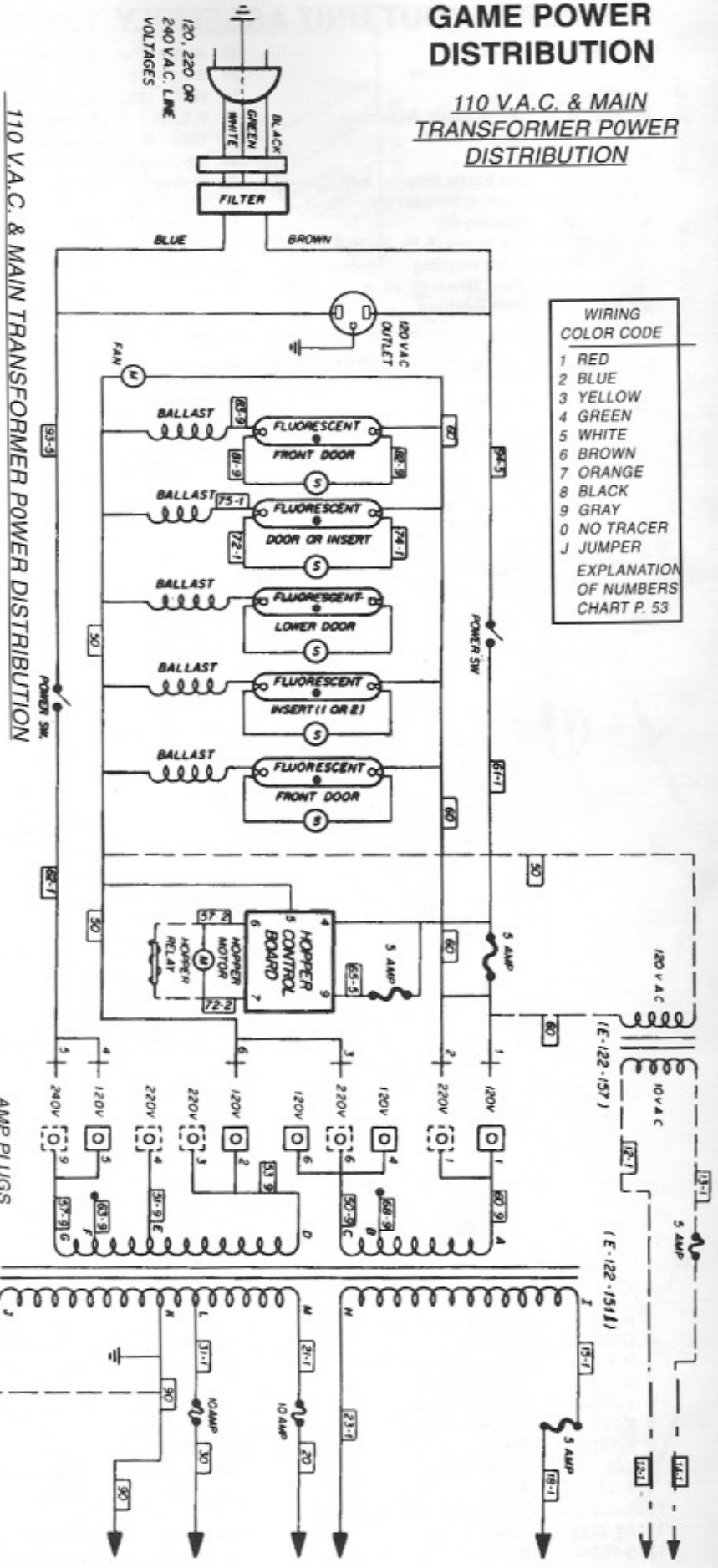

P. C. BOARD POWER DISTRIBUTION

THE SCHEMATICS ON PAGES
50-53 ARE REPRESENTATIVE
OF ALL SERIES E SLOTS

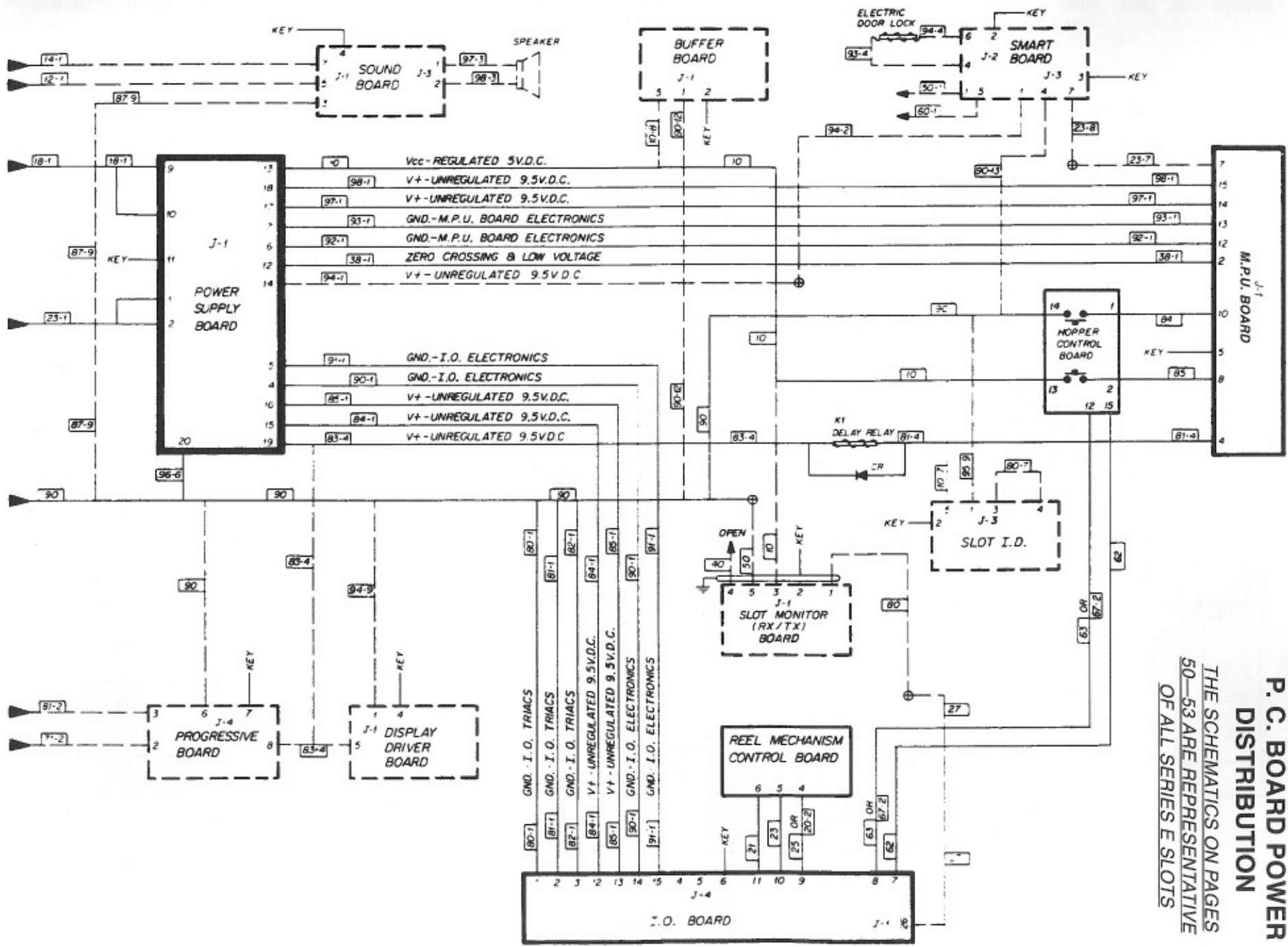

I/O BOARD J-1

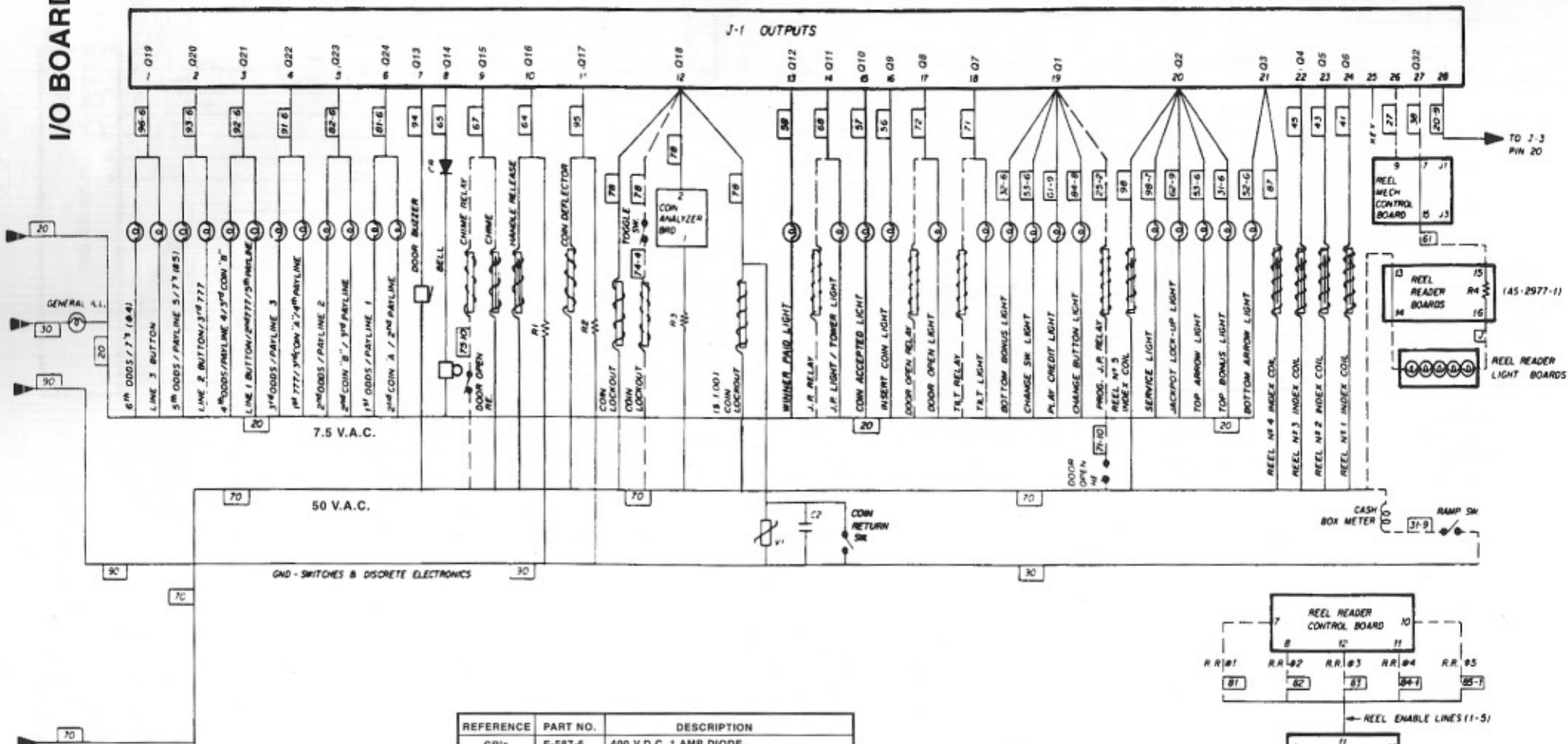

REFERENCE	PART NO.	DESCRIPTION
CR's	E-587-6	400 V.D.C. 1 AMP DIODE
C1, C2	E-586-97	1 MFD 100V POLYESTER FILM CAPACITOR
R1	E-105-6	8200 OHM 1/2 WATT 20% RESISTOR
R2	E-105-300	2700 OHM 2 WATT 10% RESISTOR
R3		520 OHM RESISTOR
R4	E-104-101	470 OHM 2 WATT 5% RESISTOR
K1	E-146-806	5 V.D.C. CR RELAY
V1	E-713-3	GE No. V100ZA3 VARISTOR

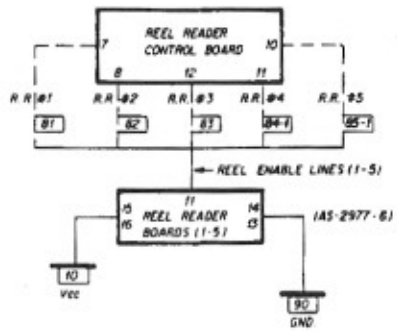

TO J-3
PIN 20

(AS-2977-1)

REEL READER
LIGHT BOARDS

(AS-2977-6)

1/0 BOARD J-2 & J-3

TERMINAL STRIPS

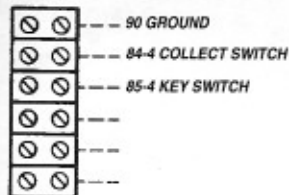

TERMINAL STRIPS

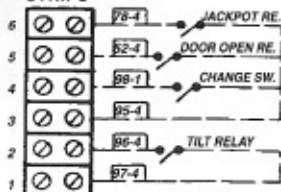

TERMINAL STRIPS

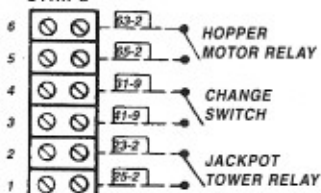

WIRE COLOR CODE

1 RED	R1. FIRST NUMBER - BODY COLOR
2 BLUE	2, SECOND NUMBER TRACER COLOR
3 YELLOW	COLOR
4 GREEN	3. NUMBER AFTER DASH INDICATES
5 WHITE	RE-USE OF THE SAME COLOR WIRE
6 BROWN	EXAMPLES
7 ORANGE	50-WHITE
8 BLACK	51-WHITE-RED
9 GRAY	51-1 WHITE-RED-(USED AGAIN)
0 NO TRACER	51-2 WHITE-RED-(USED AGAIN)
J JUMPER	27-BLUE-ORANGE
	27-1 BLUE-ORANGE-(USED AGAIN)

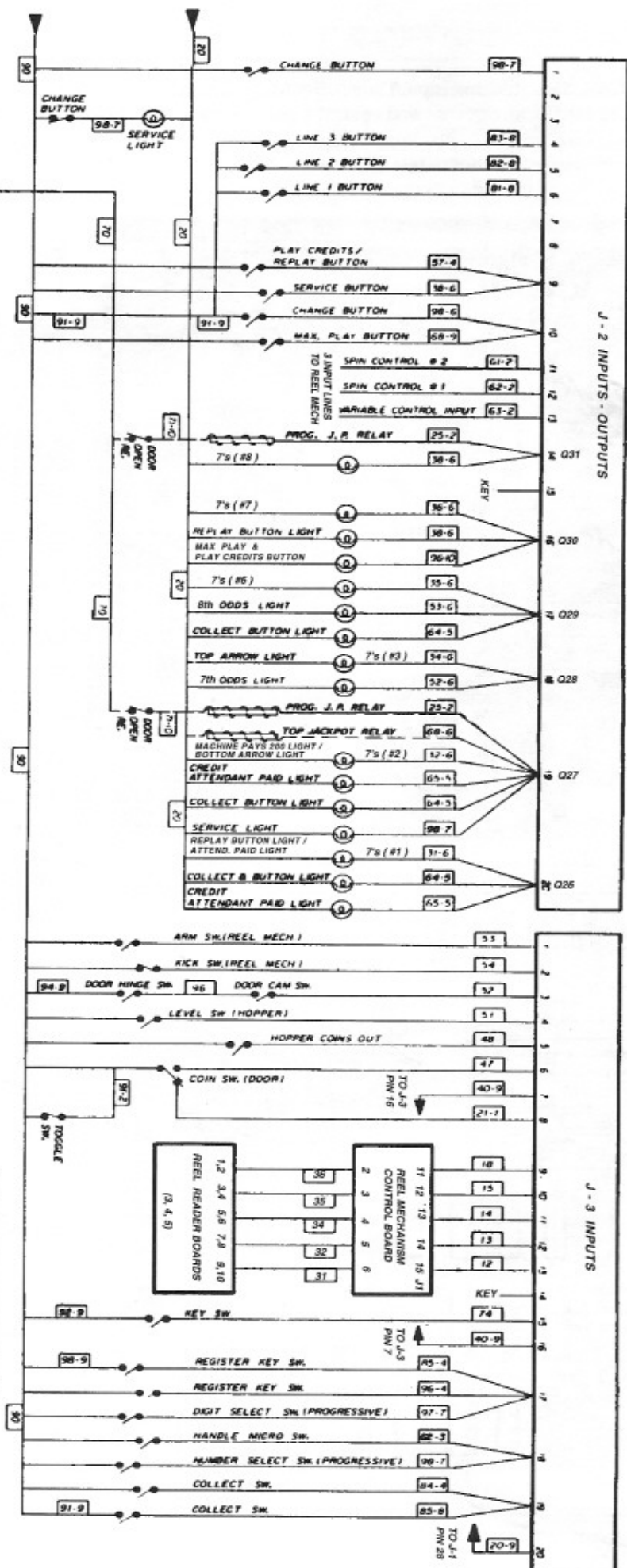

I/O BOARD ASSEMBLY

The Electronic Slot Machine Input/Output Board located behind the mechanism, p. 60), provides the circuitry to interface the MPU address, data and control signals to the slot machine peripheral devices (lamps, solenoids, switches, motors, LEDs, reel reader lights, hopper timer, etc.). Use the two Test Clips near the top left corner to test for voltage at the board. See the two previous pages for the I/O schematics and "J" 1-3 inputs/outputs.

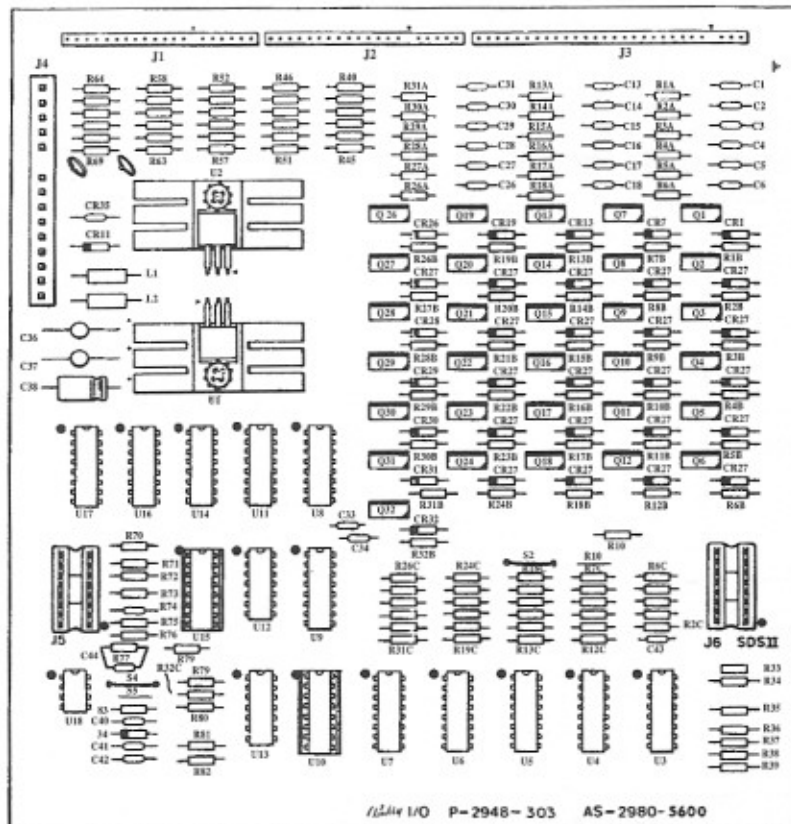
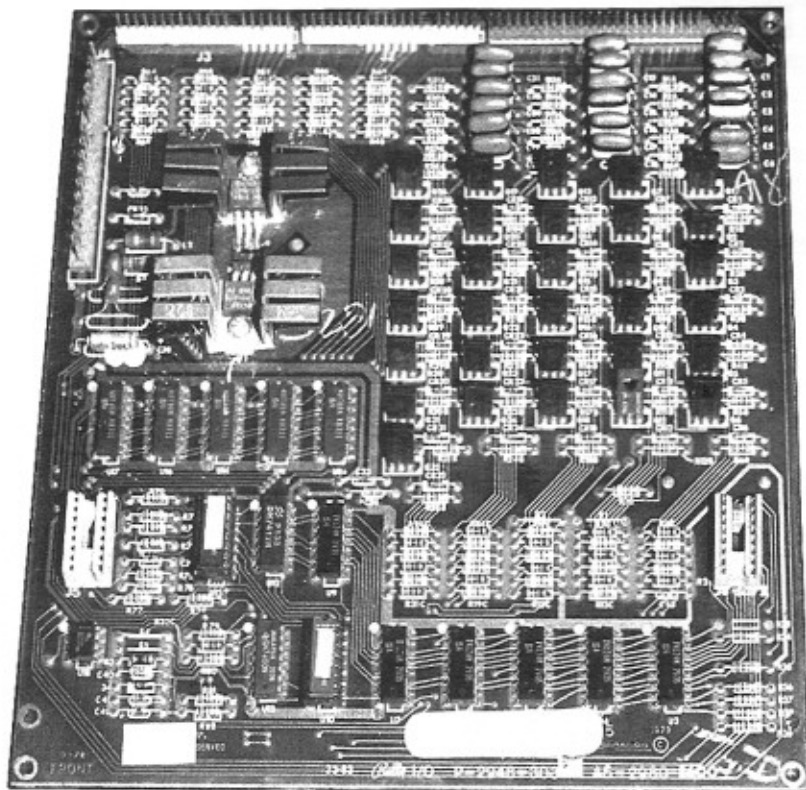

AS-2980-5600 I/O BOARD ASSEMBLY		
SYMBOL	PART NO.	DESCRIPTION
U1-U2	E-620-66	LW-340T-5 5 VDC VOLTAGE REGULATOR
	E-682-10	HEAT SINK THERMALLOY 6070
	E-682-9	HEAT SINK THERMALLOY 6071
	LSPR-632-1106	SCREW
	M-1700-6	LOCKWASHER
	N-632-2112	NUT
U3 THRU U7	E-620-64	74174 HEX D-FF
U8	E-620-70	8198 TRI-STATE HEX INVERTER
U9	E-620-84	74174 HEX D-FF
U10	E-751-4	82S123 I/O DECODER PROM #1129
	E-712-4	16 Pin D.I.P. Socket
U11	E-620-70	8198 TRI-STATE HEX INVERTER
U12	E-620-65	7417 HEX BUFFER/D.C.
U13	E-620-10	7400 QUAD 2-INPUT NAND
U14	E-620-70	8198 TRI-STATE HEX INVERTER
U15	E-751-4	82S123 I/O DECODER PROM #1129
	E-712-4	16 Pin D.I.P. Socket
U16-U17	E-620-70	8198 TRI-STATE HEX INVERTER
U18	E-620-4	555 TIMER
CR1 THRU CR24	E-587-14	1N4148 DIODE
CR25	NOT USED	
CR26 THRU CR32	E-587-14	1N4148 DIODE
CR33	EP-587-6	1N4004 DIODE
CR34	E-587-14	1N4148 DIODE
R1A THRU R8A	E-105-301	100 OHM. RESISTOR
R13A THRU R18A	E-105-301	100 OHM. RESISTOR
R26A THRU R31A	E-105-301	100 OHM. RESISTOR
R1B THRU R24B	E-105-301	100 OHM. RESISTOR
R25B	NOT USED	
R26B THRU R32B	E-105-301	100 OHM. RESISTOR
R1C THRU R24C	E-105-280	470 OHM. RESISTOR
R26C THRU R32C	E-105-280	470 OHM. RESISTOR
R33	NOT USED	
R34 THRU R39	E-105-230	1 K. OHM. RESISTOR
R40 THRU R69	E-105-280	470 OHM. RESISTOR
R70 THRU R73	E-105-230	1 K. OHM. RESISTOR
R74	NOT USED	
R75 THRU R82	E-105-230	1 K. OHM. RESISTOR
R83	E-105-285	1 M. OHM. RESISTOR
C1 THRU C6	E-586-197	.1 MFD. 200 WVDC. MET FILM
C13 THRU C18	E-586-197	.1 MFD. 200 WVDC. MET FILM
C26 THRU C31	E-586-197	.1 MFD. 200 WVDC. MET FILM
C32	NOT USED	
C33 THRU C35	E-586-85	.01 MFD. 50 WVDC. CERAMIC
C36 THRU C37	E-586-73	4.7 MFD. 25 WVDC. TANTALUM
C38	E-586-8	2 MFD. 50 WVDC. ELECTROLYTIC
C39	E-586-85	.01 MFD. 50 WVDC. CERAMIC
C40	E-586-107	.22 MFD. 50 WVDC. CERAMIC
C41 THRU C43	E-586-85	.01 MFD. 50 WVDC. CERAMIC
C44	E-586-75	820 PF. 01KV. CERAMIC
Q1 THRU Q24	E-585-44	T106A15G TRIAC
Q26 THRU Q32	E-585-44	T106A15G TRIAC
L1-L2	E-604-3	.22 MH INDUCTOR
J1	E-786-26	26 CKT. KK 100 WAFER
J2-J3	E-786-20	20 CKT. KK 100 WAFER
J4	E-736-15	15 CKT. KK 156 WAFER
SDS II - J5	E-712-8	16 PIN DIP SOCKET
(+)	P-5399	TEST CLIP (TEST POINT)
(-)	P-5399	TEST CLIP (TEST POINT)
S1	NOT USED	
S2	---	WIRE JUMPER IN CIRCUIT
S3	NOT USED	
S4	---	WIRE JUMPER IN CIRCUIT
S5	NOT USED	

ALL RESISTORS ARE 1/4 WATT 5% TOLERANCE UNLESS NOTED
RESISTOR R77 CHANGED TO E-105-279, 360 OHM, 1/4, 5%

SOUND BOARD

Found only on the Series 2000, sound is used when coins are played and paid out, when the reels are spinning and security when the door is opened. The volume is regulated by the round, black knob located near the center of the board.

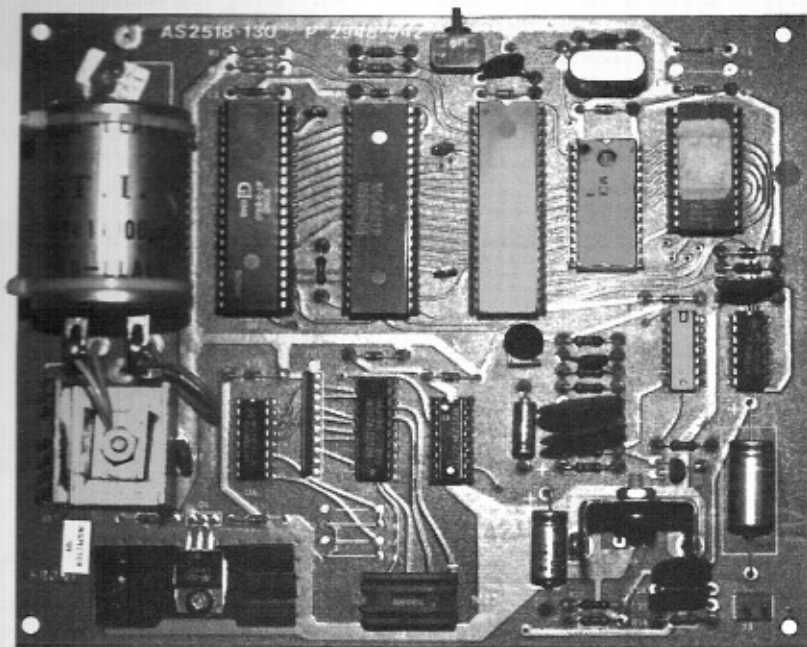
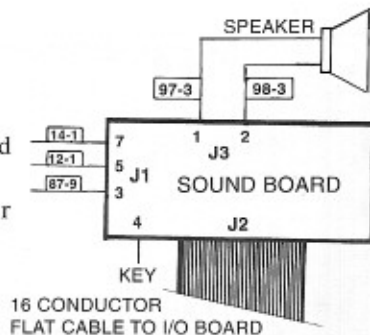

The switch at the top of the board, is used to test the board. Voltage at Test Clip TP1 should read: approx .35 VAC; TP2 approx. +2.5VDC; and TP3 approx. +2.5 VDC. TP1 & TP2 have no reading without sound.

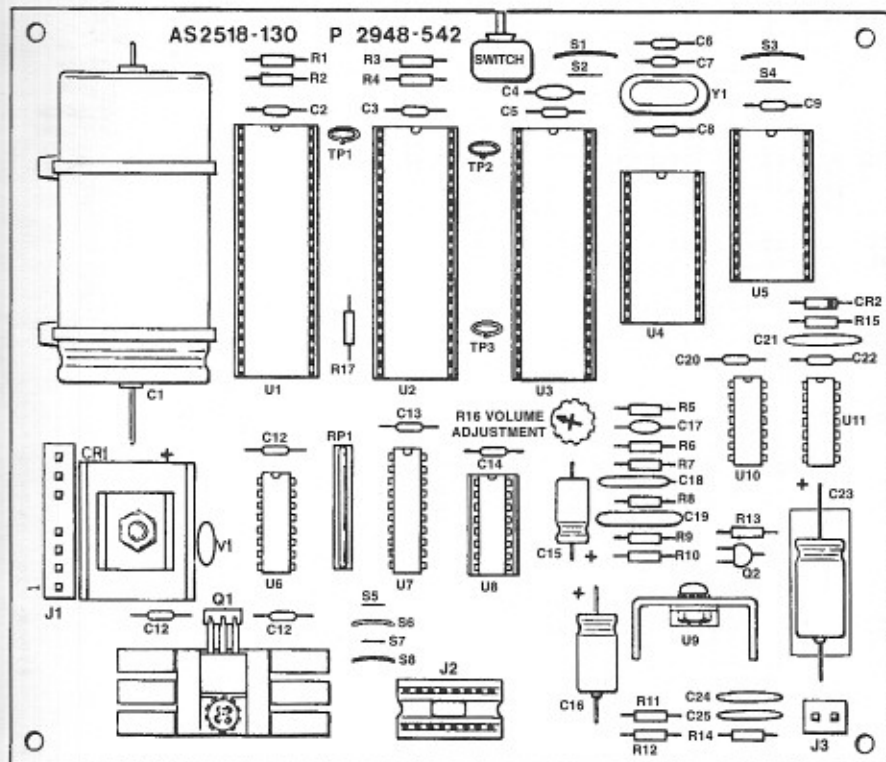

SYMBOL	PART NO.	DESCRIPTION
C1	E-586-82	11,700 MFD., 20VDC., Electrolytic
C2, 3, 5, 8, 9	E-586-85	.01 MFD., 50V., Ceramic
C10, 11, 12, 13	E-586-85	.01 MFD., 50V., Ceramic
C14, 20, 22	E-586-85	.01 MFD., 50V., Ceramic
C4	E-586-122	.001 MFD., Disc
C6, C7	E-586-121	27 PFD., Disc
C15	E-586-90	1 MFD., 25VDC., Electrolytic
C16	E-586-124	470 MFD., 6VDC., Electrolytic
C17	E-586-120	88 PFD., Disc
C18, C19	E-586-130	.47 MFD., 16V.
C21	E-586-118	.2 MFD., 16V.
C23	E-586-129	470 MFD., 16VDC., Electrolytic
C24, 25	E-586-88	.1 MFD., 25V.
CR1	E-682-3 P-6629-158 P-6629-191 LSPR-632-1106	YJ24 Bridge Rectifier Heat Sink (Small) Heat Sink (Large) Screw
CR2	M-1700-6 N-632-2112 E-587-6	Lockwasher Nut 1N4004 Diode
Q1	E-620-66 E-682-9 E-682-10 LSPR-632-1106 M-1700-6 N-632-2112	LM-340T-5 5VDC. REGULATOR Heat Sink THW-6071 (Upper) Heat Sink THW-6070 (Lower) Screw Lockwasher Nut
Q2	E-585-31	2N3904 Transistor
J1	E-735-8	8 Ckt. KK158 Wafer
J2	E-712-8	16 Pin Dip Socket
J3	E-735-2	2 Ckt. KK158 Wafer
S1, 3, 5, 6	—	Wire Jumper In Circuit
S2, 4, 5, 7	—	Not Applicable
Y1	E-713-2	G.E. 4Y22ZAI 60V
Y1	E-744-5	3.58 MHZ Quartz XTAL

AS-2518-130 SOUND BOARD		
SYMBOL	PART NO.	DESCRIPTION
U1	E-620-124 E-712-1	G.I. Sound Chip AY-3-8810 40 Pin Socket
U2	E-620-28 E-712-1	P.I.A. I.C. 6820/6821 40 Pin Socket
U3	E-620-125 E-712-1	CPU I.C. 6808 40 Pin Socket
U4	E-620-30 E-712	RAM I.C. 6810 24 Pin Socket
U5	E-661-XXXX E-712-1	Sound Personality Chip 24 Pin Socket
U6	E-620-33	I.C. 4049
U7	E-620-180	I.C. 74LS273
U8	E-751-23 E-712-4	82S123 Pwm 16 Pin Socket
U9	E-620-127 E-682-6 LSPR-632-1110	I.C. TDA2002 Heat Sink Screw
U10	M-1700-6 N-632-2112	Lockwasher Nut
U11	E-620-126 E-620-170	I.C. LM3900 I.C. 4093
R1, 2, 3, 4	E-105-238	3.3K. Ohm Resistor
R5	E-105-344	750K. Ohm Resistor
R6	E-105-225	200K. Ohm Resistor
R7	E-105-013	91K. Ohm Resistor
R8	E-105-245	30K. Ohm Resistor
R9, R17	E-105-230	1K. Ohm Resistor
R10	E-105-239	4.7K. Resistor
R11	E-105-303	220 Ohm Resistor
R12	E-105-211	2.2 Ohm Resistor
R13	E-105-185	10K. Ohm Resistor
R14	E-105-196	1 Ohm Resistor
R15	E-105-285	1M. Ohm Resistor
R16	E-589-16	Trimmer (1K. POT)
RP1	E-635-8	1K. Ohm SIP
SW1	E-658-1	Push Button PCB Switch
TP1, 2, 3	P-5399	Test Clip

M.P.U. BOARD (Microprocessor Unit)

The MICROPROCESSOR UNIT BOARD ASSEMBLY (located on the left side of the cabinet, p 60) is the controlling element of the slot machine. The photo on the left is a Series 1000 M.P.U. Unit and the diagram below is a Series 2000 M.P.U. The logic circuitry contained on these boards performs many functions which are similar to other microprocessor systems, but in addition, specialized circuits are utilized for security and versatility.

The CPU (U15) is the heart of the MPU Board. This Integrated Circuit (I.C.) performs such functions as retrieving instructions coded in memory EPROMs, interpreting the instructions, processing any arithmetic and logic operation required and manipulating control and buss signals.

The PERSONALITY PROM (U12) is unique to each game. It determines the type of machine (line or multiplier), number of coins played and the amount of individual pays. The payout percentage of a slot may be altered by changing this Prom. A second PERSONALITY PROM (U13), found only on Series 2000, is not necessary in most games. It is used when there are a number of extra pays or if the machine has a progressive jackpot.

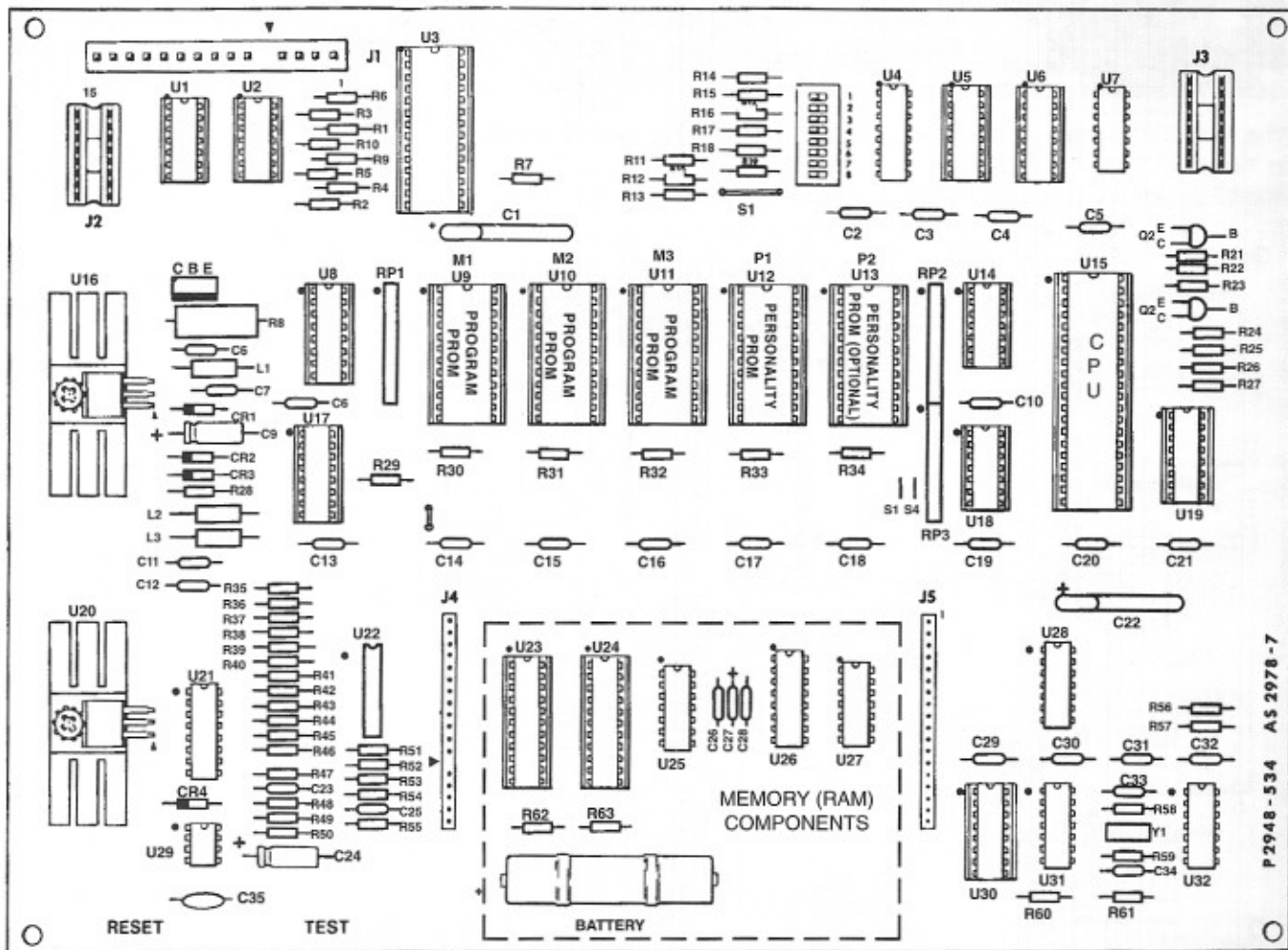
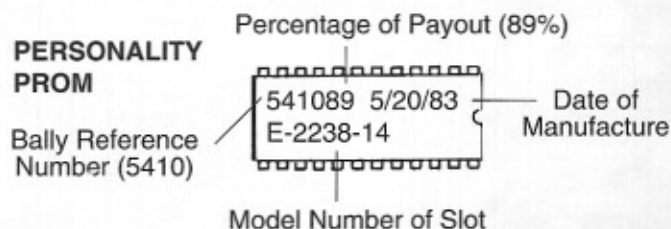
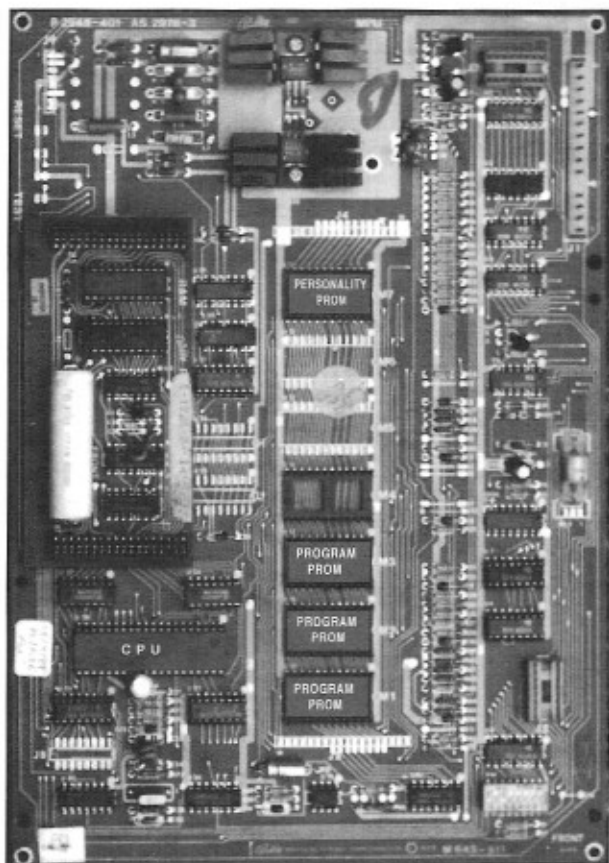

SERIES 1000 M. P. U. BOARD (Parts Descriptions)

AS-2978-3 MPU BOARD ASSEMBLY								
SYMBOL	PART NO.	DESCRIPTION	SYMBOL	PART NO.	DESCRIPTION	SYMBOL	PART NO.	DESCRIPTION
U1	E-00620-0063	74145 I.C. BCD TO DECIMAL DECODER	Q1	E-00585-0002	MPS 6566 NPN TRANSISTOR	C18 - C20	E-00586-0005	.01 MFD., 50 V. CERAMIC
U2	E-00620-0061	7448 I.C. BCD TO 7-SEG. DECODER	Q2	E-00585-0004	MPS 6517 PNP TRANSISTOR	C21	E-00586-0009	33 MFD., 25 V. ELECTROLYTIC
U3 - U4	E-00620-0064	74174 I.C. HEX D-FF	Q3	E-00585-0002	MPS 6566 NPN TRANSISTOR	C22	E-00586-0005	.01 MFD., 50 V. CERAMIC
U5	E-00620-0062	74LS132 I.C. QUAD SCHMITT TRIGGER	CR1	E-00587-0006	1N4004 DIODE	C23	E-00586-0094	470 PFD., 1 K V. CERAMIC
U6	E-00620-0067	4020 I.C. COUNTER	CR2	DELETED		C24	E-00586-0093	10 PFD., 1 K V. CERAMIC
U7 - U8	E-00712-0004	16 PIN DIP SOCKET	CR3	E-00587-0014	1N4148 DIODE	C25	E-00586-0095	1000 PFD., 1 K V. CERAMIC
	E-00620-0068	8128 I.C. TRI-STATE TRANSCIEVER	CR4 -	E-00587-0006	1N4004 DIODE	C26 - C28	E-00586-0073	4.7 MFD., 25 V. TANTALUM
	E-00712-0004	16 PIN DIP SOCKET	R1	E-00105-0230	1 K OHM RESISTOR	L1 - L3	E-00604-0003	.22 MH INDUCTOR
U9	E-00620-0069	8197 I.C. TRI-STATE TRANSCIEVER	R2	E-00105-0263	47 K OHM RESISTOR	RLY1	E-00146-0796	ELECTRO #RA31441051 REED RELAY
U10	E-00620-0060	74LS04 I.C. HEX INVERTER	R3	DELETED		SW	E-00677-0000	8 POSITION DIP SWITCH
U11	EMR0-42716	2716 (INTEL) I.C. EPROM (M-7)	R4	E-00105-0230	1 K OHM RESISTOR	YR1	E-00586-0013	1N4733 ZENER DIODE
	E-00712-0000	24 PIN DIP SOCKET	R5	E-00105-0185	10 K OHM RESISTOR	Y1	E-00744-0000	4 MHZ CRYSTAL
U12 U13	NOT USED		R6 - R9	E-00105-0230	1 K OHM RESISTOR	J1	E-00736-0015	15 OXT. KK 156 WAFER
U14	E-00712-0000	24 PIN DIP SOCKET	R10	DELETED		J2 - J3	E-00712-0008	16 PIN DIP SOCKET
U15	E-755-10	9316 I.C. ROM (M-3)	R11 - R25	E-00105-0230	1 K OHM RESISTOR	J4	NOT USED	
	E-00712-0000	24 PIN DIP SOCKET	R26	DELETED		J5	NOT USED	
U16	E-755-9	9316 I.C. ROM (M-2)	R27 - R29	E-00105-0303	220 OHM RESISTOR	J6 + J7	E-00770-0018	18 OXT. KK 100 WAFER
	E-00712-0000	24 PIN DIP SOCKET	R30 - R38	E-00105-0230	1 K OHM RESISTOR	J8 - J9	NOT USED	
U17	E-755-8	9316 I.C. ROM (M-1)	R39 - R42	E-00105-0303	220 OHM RESISTOR	+	(TEST POINT)	P-5399 TEST CLIP
	E-00712-0000	24 PIN DIP SOCKET	R43	E-00105-0230	1 K OHM RESISTOR	-	(TEST POINT)	P-5399 TEST CLIP
U18	E-00620-0004	555 I.C. TIMER	R44 - R45	E-00105-0303	220 OHM RESISTOR	S1	WIRE JUMPER IN CIRCUIT	
U19	E-00620-0067	4020 I.C. COUNTER	R46 - R47	E-00105-0230	1 K OHM RESISTOR	S2 THRU S9	NOT USED	
	E-00712-0004	16 PIN DIP SOCKET	R48	E-00105-0304	510 K OHM RESISTOR	S10	WIRE IN JUMPER CIRCUIT	
U20	E-00620-0011	7402 I.C. QUAD NOR GATE	R49	E-00105-0230	1 K OHM RESISTOR	S11	NOT USED	
U21	E-00751-0003	825123 INTERRUPT PROM	R50	E-00105-0263	47 K OHM RESISTOR	S12	WIRE IN JUMPER CIRCUIT	
	E-00712-0004	16 PIN DIP SOCKET	R51	E-00105-0301	100 OHM RESISTOR	S13	NOT USED	
U22 U23	NOT USED		R52	NOT USED		AS-2979-1 RAM BOARD ASSEMBLY		
U24	E-00620-0065	7417 I.C. HEX BUFFER	R53 - R60	E-00105-0185	10 K OHM RESISTOR	SYMBOL	PART NO.	DESCRIPTION
	E-00712-0005	14 PIN DIP SOCKET	R61 - R73	E-00105-0230	1 K OHM RESISTOR	U1 - U2	E-00620-0042	P5101L-3 RAM (10MS)
U25	E-00751-0012	825123 MEMORY ADDR. PROM	R74 - R75	E-00105-0185	10 K OHM RESISTOR		E-00712-0003	22 PIN DIP SOCKET
	E-00712-0004	16 PIN DIP SOCKET	R76	E-00105-0230	1 K OHM RESISTOR	U3	E-00620-0081	74LS30 EIGHT - INPUT NAND
U26	E-00620-0060	74LS04 I.C. HEX INVERTER	R77 - R78	E-00105-0277	680 OHM RESISTOR	U4	E-00620-0086	74166 EIGHT - BIT SHIFT REGISTER
U27	E-00620-0065	7417 I.C. HEX BUFFER				U5	E-00620-0080	74LS27 TRIPLE 3 - INPUT NOR
	E-00712-0005	14 PIN DIP SOCKET	C1	DELETED		R1	E-00105-0301	100 OHM RESISTOR 1/4 WATT 5%
U28	E-00620-0053	2650A I.C. CPU	C2	E-00586-0085	.01 MFD., 50 V. CERAMIC	R2	NOT USED	
	E-00712-0001	40 PIN DIP SOCKET	C3 - C4	E-00586-0099	33 MFD., 25 V. ELECTROLYTIC	C1	E-00586-0085	.01 MFD., 50 V. CERAMIC
U29	E-00751-0001	825123 CONTROL PROM	C5 - C11	E-00586-0085	.01 MFD., 50 V. CERAMIC	C2	E-00586-0073	.01 MFD., 25 V. TANTALUM
	E-00712-0004	16 PIN DIP SOCKET	C12	DELETED		C3	E-00586-0094	470 PFD., 50 V. CERAMIC
U30	E-00620-0025	7474 I.C. DUAL D-FF	C13	E-00586-0008	2 MFD., 50 V. ELECTROLYTIC	B1	E-00628-0003	BATTERY
U31 - U32	E-00620-0066	LM-340T-5.0 5 VDC REGULATOR	C14	E-00586-0085	.01 MFD., 50 V. CERAMIC	J1 - J2	E-00771-0018	18 OXT. KK100 BOTTOM ENTRY CONNECTOR
	E-00682-0010	HEAT SINK - THM 6070	C15	E-00586-0008	2 MFD., 50 V. ELECTROLYTIC			
	E-00682-0009	HEAT SINK - THM 6071	C16 - C17	E-00586-0073	4.7 MFD., 25 V. TANTALUM			

SERIES 2000 M. P. U. BOARD (Parts Descriptions)

AS-2978-7 M.P.U. BOARD ASSEMBLY								
SYMBOL	PART NO.	DESCRIPTION	SYMBOL	PART NO.	DESCRIPTION	SYMBOL	PART NO.	DESCRIPTION
U1, U2	E-881-1	I.C. CA3274 NPN Trans. Array	U21	E-881	I.C. 3081 NPN Transistor Array	R48	E-105-304	510K Ohm Resistor
	E-712-5	14 Pin D.I.P. Socket	U22	E-828-189	I.C. 14008 Quad Analog Switch	R49	E-105-283	47K Ohm Resistor
U3	E-828-244	I.C. J4C812 Display Controller/Dr.	U23, U24	E-828-42	I.C. P-5101L-3 CMOS Rom	R50	E-105-230	1K Ohm Resistor
	E-712-28	28 Pin D.I.P. Socket	U25	E-712-3	22 Pin D.I.P. Socket	R51	E-105-185	10K Ohm Resistor
U4	E-828-89	I.C. 8197 Tri-State Buffer	U26	E-828-81	I.C. 74LS30 Eight Input NAND	R52	E-105-230	1K Ohm Resistor
U5, U8	E-828-88	I.C. 8128 Tri-State Transceiver	U28	E-828-88	I.C. 74198 Eight Bit S.R.	R53, R54	E-105-185	10K Ohm Resistor
	E-712-4	16 Pin D.I.P. Socket	U27	E-828-80	I.C. 74LS27 Triple Input Nor	R55	E-105-230	1K Ohm Resistor
U7	E-828-10	I.C. 7404 Hex Inverter	U28	E-828-170	I.C. 14093 Quad Schmitt Trigger	R56, R57	E-105-185	10K Ohm Resistor
U8	E-751-3	I.C. 825123 Interrupt Decoder Prom	U29	E-828-4	I.C. 555 Timer	R58, R59	E-105-277	680 Ohm Resistor
	E-712-4	16 Pin D.I.P. Socket	U30	E-828-87	I.C. 14020 Counter	R60, R61	E-105-185	10K Ohm Resistor
U9 *	E-795 Series	I.C. Memory (M-1)	U31	E-712-4	16 Pin D.I.P. Socket	R62	E-105-381	100 Ohm Resistor
	E-712	24 Pin D.I.P. Socket	U31	E-828-26	I.C. 7474 Dual D-FF	R63	Not used	
U10 *	E-755 Series	I.C. Memory (M-2)	U32	E-828-60	I.C. 74LS34 Hex Inverter	RPI Thru RPS	E-835-9	10K SIP (18 Pin) (Pull-Up)
	E-712	24 Pin D.I.P. Socket	Q1	E-585-75	84083 NPN Darlington Trans.	C1	E-586-148	47 mfd. 16V. Electrolytic
U11 *	E-756 Series	I.C. Memory (M-3)	Q2	E-585-4	MPS8517 PNP Transistor	C2 Thru C8	E-586-85	.01 mfd. 25V. Ceramic
	E-712	24 Pin D.I.P. Socket	Q3	E-585-2	MPS8566 NPN Transistor	C9	E-586-9	2 mfd. 25V. Min. Electrolytic
U12	E-712	24 Pin D.I.P. Socket (P-1)	CR1 Thru CR3	E-587-8	1N4004 Diode	C10 Thru C21	E-586-85	.01 mfd. 25V. Ceramic
U13	E-712	24 Pin D.I.P. Socket (P-2)	CR4	E-588-19	6.2V. 1s Zener Diode	C22	E-586-148	47 mfd. 16V. Electrolytic
U14	E-828-85	I.C. 7417 Hex Buffer	R1 Thru R8	E-105-301	100 Ohm Resistor	C23	E-586-85	.01 mfd. 25V. Ceramic
	E-712-5	14 Pin D.I.P. Socket	R7	E-105-230	1K Ohm Resistor	C24	E-688-8	2 mfd. 25V. Min. Electrolytic
U15	E-828-53	I.C. 2080 CPU	R8	E-105-408	16 Ohm 1W. 5% Carbon Resistor	C25, C26	E-586-85	.01 mfd. 25V. Ceramic
	E-712-1	40 Pin D.I.P. Socket	R9, R16	E-105-301	100 Ohm Resistor	C27	E-586-73	4.7 mfd. Tantalum
U16	E-828-86	LM-340T-5 5VDC Regulator	R11 Thru R19	E-105-283	47K Ohm Resistor	C28	E-586-94	470 pfd. Ceramic
	E-882-18	Heat Sink THM-8070 (Upper)	R20	DELETED		C29 Thru C32	E-586-85	.01 mfd. 25V. Ceramic
	E-882-9	Heat Sink THM-8071 (Lower)	R21	E-105-189	10K Ohm Resistor	C33	E-586-83	10 pfd. Ceramic
	LSPB-832-1186	Scram	R22	E-105-230	1K Ohm Resistor	C34	E-586-85	1000 pfd. Ceramic
	M-1700-8	Lockwasher	R23	E-105-283	47K Ohm Resistor	C35	E-586-44	.1 mfd. 100V. Polyester
	M-832-2117	Nut	R24 Thru R27	E-105-230	1K Ohm Resistor	L1 Thru L3	E-884-3	.22 MH Inductor
U17	E-751-27	I.C. 825123 Memory Address Decoder Prom	R28	E-105-301	100 Ohm Resistor	Dip Switch	E-877	(8) SPST
	E-712-4	16 Pin D.I.P. Socket	R29 Thru R34	E-105-230	1K Ohm Resistor	Test-Reset	Not used	
U18	E-828-83	I.C. 7417 Hex Buffer	R35	E-105-185	10K Ohm Resistor	Y1	E-744	4 MHZ Quartz Crystal
	E-712-5	14 Pin D.I.P. Socket	R36	E-105-129	1.5K Ohm Resistor	Y1	E-738-15	15 Pin XL156 Wafer
U19	E-751-21	I.C. 825123 Control Decoder Prom	R37	E-105-185	10K Ohm Resistor	J2, J3	E-712-8	16 Pin Dip Socket
	E-712-4	16 Pin D.I.P. Socket	R38	E-105-230	1K Ohm Resistor	J4, J5	Not used	
U20	E-828-88	LM-340T-5 5VDC Regulator	R39	E-105-185	10K Ohm Resistor	B1	E-628-4	Battery (3.0 VDC. NI-CAD.)
	E-882-19	Heat Sink THM-8070	R40, R40	E-105-332	3K Ohm Resistor	S1	WIRE JUMPER IN CIRCUIT	
	E-882-9	Heat Sink THM-8071	R44	E-105-185	10K Ohm Resistor	S2	WIRE JUMPER IN CIRCUIT	
	LSPB-832-1186	Scram	R45	E-105-235	180 Ohm Resistor	S3	WIRE JUMPER IN CIRCUIT	
	M-1700-8	Lockwasher	R46	E-105-408	16 Ohm Resistor	S4	NOT USED	
	M-832-2117	Nut	R47	E-105-189	10K Ohm Resistor			

NOTE: All Resistors are Carbon Type, 1/4 W. 5% Unless Noted.
U18 & U20; Use Thermal Compound as Needed.

* Universal Slot Program (USP) Versions will vary.

POWER SUPPLY BOARD

This board provides the slot machine with two power sources and one signal source. They are V+ (10.5 VDC), VCC (+5VDC) and the zero crossing signal. The latter are generated by converting 9.5 to 11 volts AC secondary voltage from the Game Transformer.

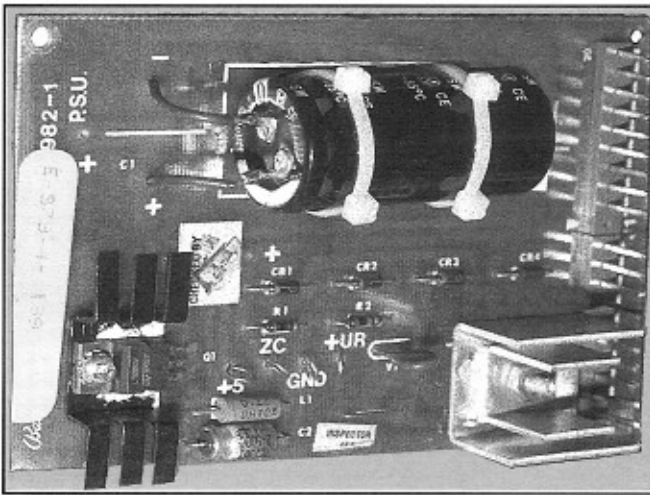
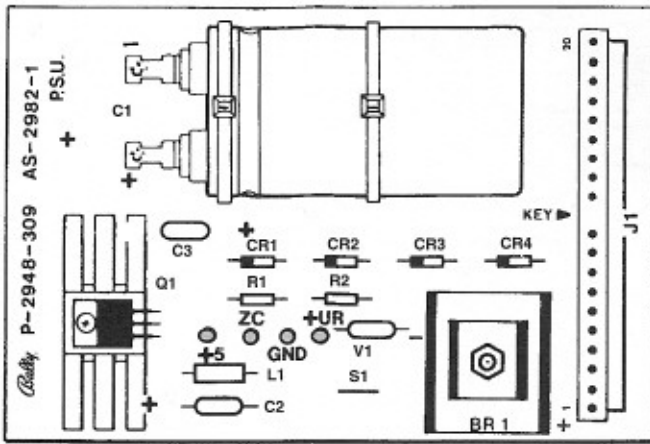

AS-2982-1 POWER SUPPLY BOARD ASSEMBLY

SYMBOL	PART NO.	DESCRIPTION
Q1	E-620-66	LM-340T-5 5 V.D.C. VOLTAGE REGULATOR
	E-662-10	HEAT SINK THERMALLOY 6070
	LSPR-632-1106	SCREW
	M-1700-6	LOCKWASHER
	N-632-2112	NUT
BR1	E-602-3	V124B BRIDGE RECTIFIER
	P-6629-158	HEAT SINK (LARGE)
	P-6629-191	HEAT SINK (SMALL)
	LSPR-632-1110	SCREW
	M-1700-6	LOCKWASHER
CR1 THRU CR4	N-632-2112	NUT
	E-587-6	1N4004 DIODE
	E-713-2	G.E. V222A1 M.G.V.
	E-105-238	1 K. OHM. RESISTOR 1/4 WATT 5%
	E-105-185	10 K. OHM. RESISTOR 1/4 WATT 5%
C1	E-586-62	11,700 MFD. 20 V. ELECTROLYTIC
C2	E-647-5	TIE WRAP (TWO USED)
C3	E-586-8	2 MFD. 50 V. ELECTROLYTIC
L1	NOT USED	
L1	E-604-3	.22 M.H. INDUCTOR
TP1 THRU TP4	P-5399	TEST CLIP (TEST POINT)
J1	E-736-10	10 CKT. KK156 WAFER (2)
S1		WIRE JUMPER IN CIRCUIT

TESTING THE POWER SUPPLY BOARD

Using a Volt-Ohm meter, check the three secondary voltages with one lead on the ground ((GND) Test clip (TP3) and the other lead on one of the 3 other Test Clips (looped wires).

● +5 ● ZC ● GND ● +UR

TP1 (+5) to TP3 (GND) — Approx. +5.0 Volts DC
 TP2 (ZC) to TP3 (GND) — Approx. +7.5 Volts DC
 TP4 (+UR) to TP3 (GND) — Approx. +10 Volts DC

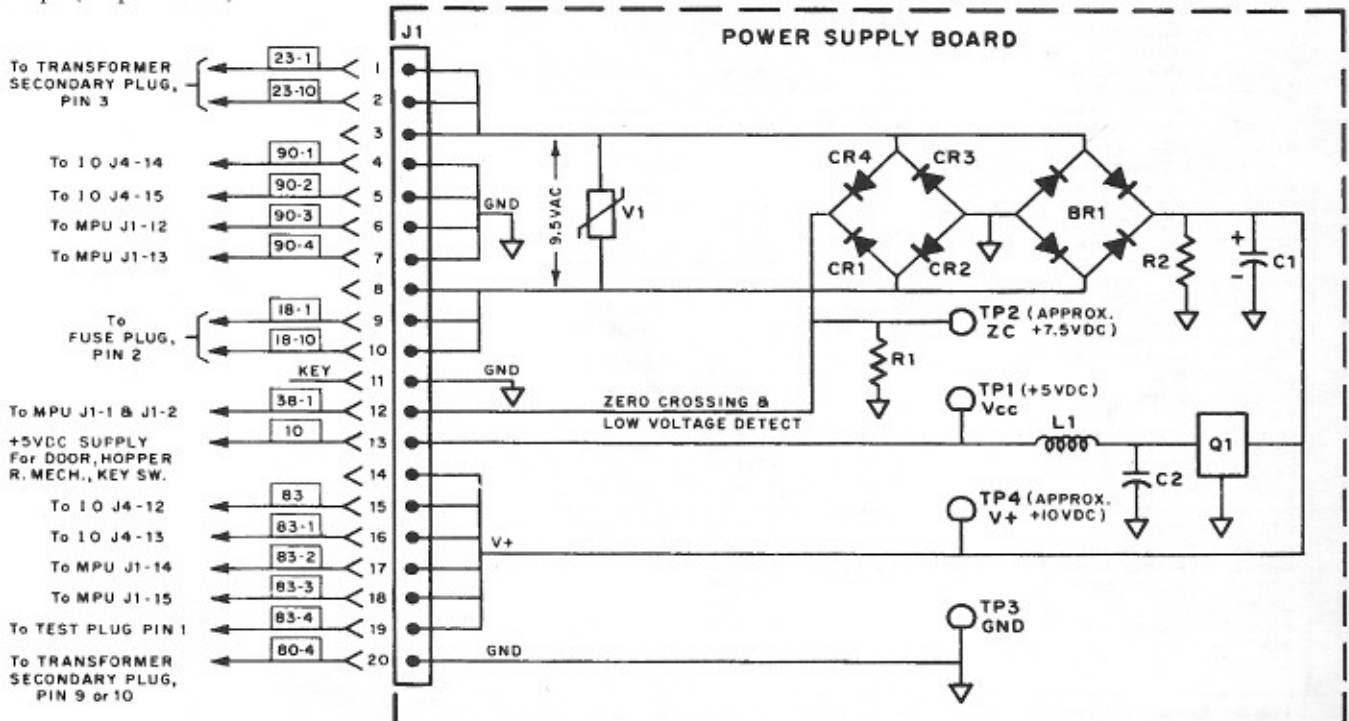

DELAY RELAY BOARD

Located behind the Hopper, the Delay Relay Board was used only on the Series 1000. It was replaced by an encapsulated CR Relay, located near the Hopper Beau Plug. For the description and the operation of the Delay Relay Board see page 61.

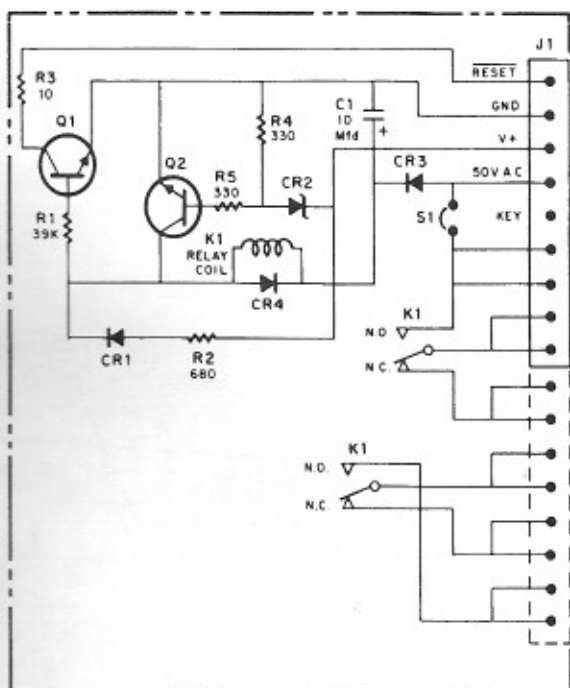

SYMBOL	PART NO.	DESCRIPTION
C1	E-586-149	Axial 10mfd \pm 100V. Cap.
CR1	E-587-6	1N4004 Diode
CR2	E-598-19	6.3V. \pm 2ma 1% Zener
CR3	E-587-6	1N4004 Diode
CR4	E-587-6	1N4004 Diode
J1	E-756-9	9 Pin KK 156 Conn
K1	E-146-795	48VDC Relay
P.C.	P-2948-472	P.C. Board M-645-606
Q1	E-585-71	2N4401 Transistor
Q2	E-585-33	MPS-A42 Transistor
R1	E-105-231	39K Ohm 1/4 Watt 5%
R2	E-105-277	680 Ohm 1/4 Watt 5%
R3	E-105-306	10 Ohm 1/4 Watt 5%
R4	E-105-219	330 Ohm 1/4 Watt 5%
R5	E-105-219	330 Ohm 1/4 Watt 5%
S1	—	Wire Jumper Installed

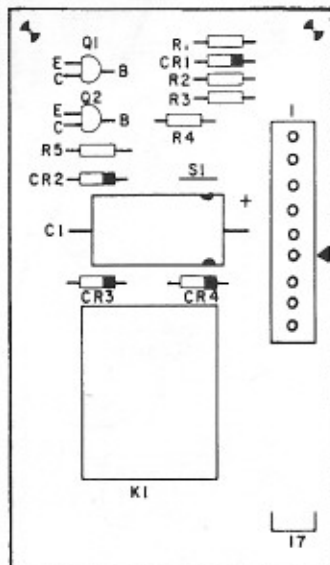

SLOT SIMULATOR TEST STATION

REEL MECHANISM ASSEMBLY
Includes: REEL CONTROL BOARD, AS-2983-1
or REEL CONTROL BOARD, AS-2983-2
REEL READER BOARD, AS-2977-1
or REEL READER BOARD, AS-2977-6

HOPPER PAYOUT UNIT ASSEMBLY - Includes:
HOPPER CONTROL BOARD
AS-2981-5

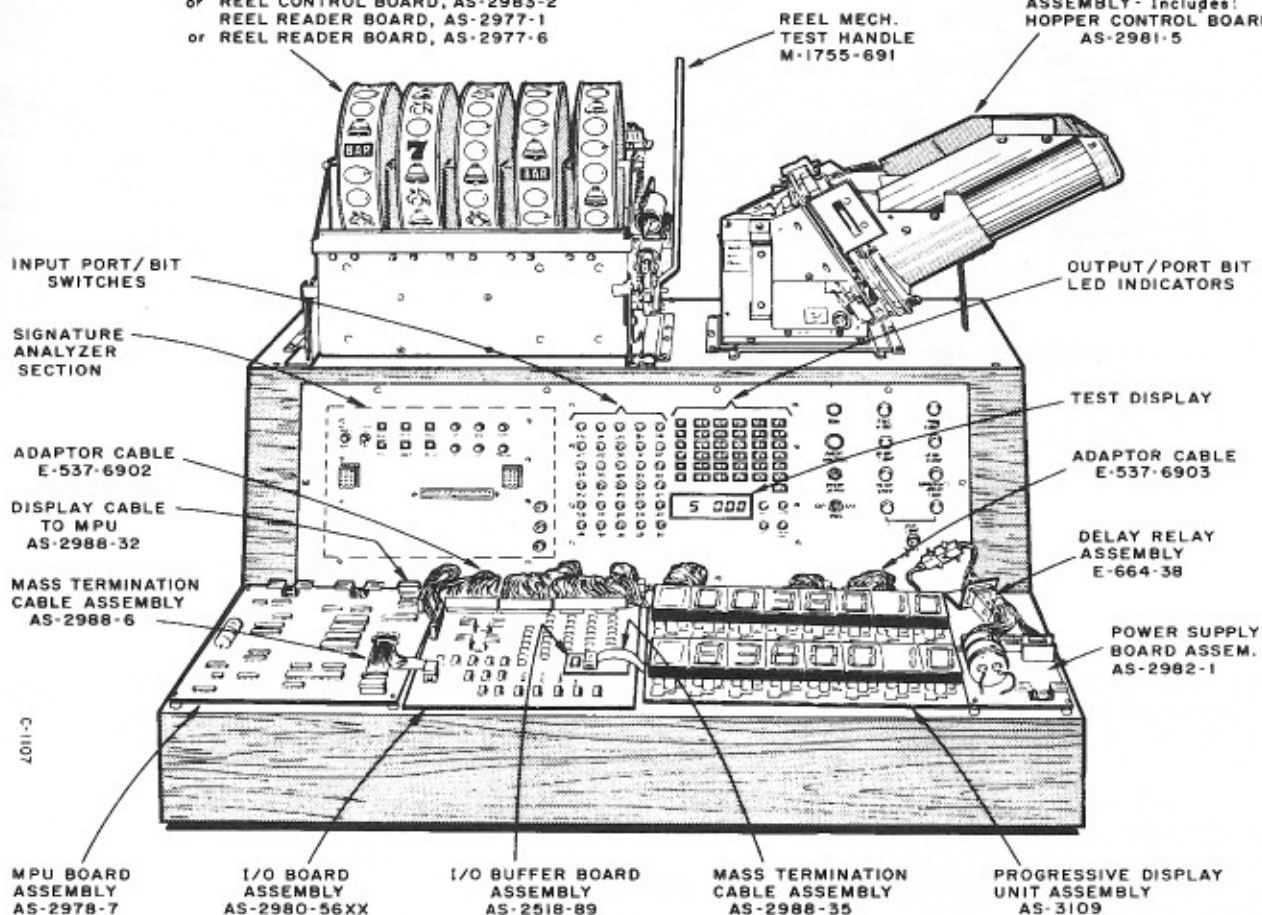

The best way to check a defective board, or boards, it is have a qualified technician inspect them on a Slot Simulator Test Station. This device simulates the operating functions used on all Series E Slot Machines.

CABINET CABLING CONNECTIONS

AS-2985-2
DISPLAY BOARD

AS-2978-7
MPU BOARD

PLUGS INTO SLOT
I.D. BOARD (Optional)

PLUGS INTO
FRONT DOOR
CABLE

PLUGS INTO
"SMART" BOARD
(Optional)

CONNECTS TO
HINGE SWITCH

PLUGS FOR
MISER BOARD
(Optional)

DELAY RELAY

HOPPER
BEAU PLUG

POWER SWITCH

AS-2950-5600
I/O BOARD

AS-2982-1
POWER
SUPPLY
BOARD

INSERT & LAMP
SOCKET ASSEMBLY

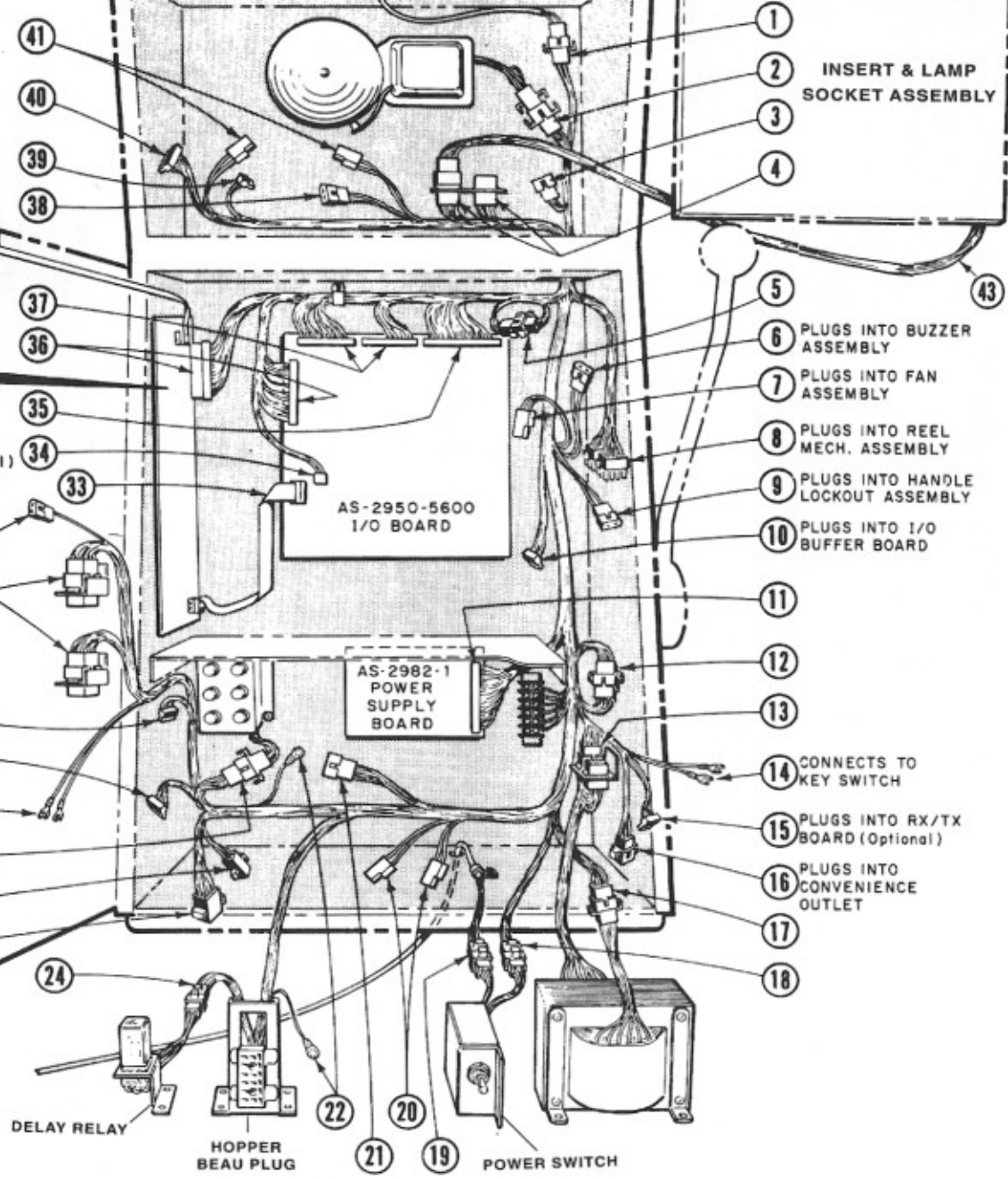

ITEM	PART NO.	DESCRIPTION
1	E-662-401	4 Pt. Molex Receptacle
2	E-660-401	4 Pt. Molex Plug
3	E-660-200	2 Pt. Molex Plug
4	E-662-1201	12 Pt. Molex Receptacle
5	E-662-401	4 Pt. Molex Receptacle
6	E-660-401	4 Pt. Molex Plug
7	E-660-200	2 Pt. Molex Plug
8	E-662-200	2 Pt. Molex Receptacle
9	E-808-12	12 Ckt. AMP Plug-White
10	E-808-212	12 Ckt. AMP Plug-Red
11	E-807	AMP Socket
12	E-660-200	2 Pt. Molex Plug
13	E-737-5	5 Pin MTA-100 Connector
14	E-775-5	5 Pin MTA-100 Cover
15	E-856-20	20 Pin MTA-156 Connector
16	E-749-20	20 Pin MTA-156 Cover
17	E-660-1200	12 Pt. Molex Plug
18	E-662-1201	12 Pt. Molex Receptacle
19	E-660-1200	12 Pt. Molex Plug
20	P-405-75	O.C. Terminal
21	E-737-5	5 Pin MTA-100 Connector
22	E-775-5	5 Pin MTA-100 Cover
23	E-662-401	4 Pt. Molex Receptacle
24	E-660-1200	12 Pt. Molex Plug
25	E-660-401	4 Pt. Molex Plug
26	E-660-401	4 Pt. Molex Plug
27	E-662-200	2 Pt. Molex Receptacle
28	E-660-1200	12 Pt. Molex Plug
29	P-405-31	Terminal
30	E-126-43	Line Cord
31	E-662-401	4 Pt. Molex Receptacle
32	E-662-1201	12 Pt. Molex Receptacle
33	E-662-401	4 Pt. Molex Receptacle
34	E-660-1200	12 Pt. Molex Plug
35	P-405-74	O.C. Terminal
36	E-737-10	10 Pin MTA-100 Connector
37	E-775-10	10 Pin MTA-100 Cover
38	E-737-6	6 Pin MTA-100 Connector
39	E-775-6	6 Pin MTA-100 Cover
40	E-660-1200	12 Pt. Molex Plug (2)
41	E-660-200	2 Pt. Molex Plug
42	AS-2988-5	Mass-Term Cable Assem.
43	E-711	16 Conductor Flat Cable
	E-719	D.I.P. Connector
	E-695	Strain Relief
	E-696	Pull Tabs
	E-737-5	5 Pin MTA-100 Connector
	E-775-5	5 Pin MTA-100 Cover
	E-737-28	28 Pin MTA-100 Connector
	E-775-28	28 Pin MTA-100 Cover
	E-856-15	15 Pin MTA-156 Connector
	E-749-15	15 Pin MTA-156 Cover
	E-773	Key
	E-737-20	20 Pin MTA-100 Connector
	E-775-20	20 Pin MTA-100 Cover
	E-774	Key
	E-660-200	2 Pt. Molex Plug
	E-856-2	2 Pin MTA-156 Connector
	E-749-2	2 Pin MTA-156 Cover
	E-856-8	8 Pin MTA-156 Connector
	E-749-8	8 Pin MTA-156 Cover
	E-662-200	2 Pt. Molex Receptacle
	AS-2987-9	Display & Cable Assem.
	E-537-XXX	Insert Assem. Cable (Specify Model No.)

TRIACS



The example shown at right is for a 5-line, 10-way pay.

The Triacs Q1-Q32, located in five rows on the I/O Board, are the electronic switches that control the operations of the game. For their various combinations of uses refer to the I/O Board schematics on pages 52 and 53.

All 32 Triacs use the Bally part number E-585-44 which is a T106A1SG Triac. These components are available from the Wico Corporation. Their replacement number is Wico 21-311100.

TOP ROW 7'S LEFT LAMP Q 26	MIDDLE ROW 7'S LEFT & RIGHT LAMPS Q 19	DOOR ALARM BUZZER Q 13	TILT LAMP Q 7	OPTIONAL LAMPS (NOT USED) Q 1
TOP ROW 7'S CENTER LAMP Q 27	MIDDLE ROW 7'S CENTER LAMPS Q 20	BELL Q 14	DOOR OPEN LAMP Q 8	FEATURE LAMPS Q 2
TOP ROW 7'S RIGHT LAMP Q 28	PAYLINE #5 LAMP Q 21	BELL / CHIME Q 15	INSERT COIN LAMP Q 9	FEATURE LAMPS (ALSO USED FOR REEL #4 SOLENOID) Q 3
BOTTOM ROW 7'S LEFT LAMP Q 29	PAYLINE #4 LAMP Q 22	HANDLE RELEASE COIL Q 16	COIN ACCEPTER LAMP Q 10	REEL #3 SOLENOID Q 4
BOTTOM ROW 7'S CENTER LAMP Q 30	PAYLINE #3 LAMP Q 23	COIN DEFLECTOR COIL Q 17	TOWER LAMP Q 11	REEL #2 SOLENOID Q 5
BOTTOM ROW 7'S RIGHT LAMP Q 31	PAYLINE #2 LAMP Q 24	COIN LOCKOUT COIL Q 18	WINNER PAID LAMP Q 12	REEL #1 SOLENOID Q 6
REEL READER LIGHTS Q 32	TRIAC FUNCTION CHART SOME TRIACS ARE NOT ALWAYS USED. TRIACS IN BOLD ARE COMMON TO ALL SLOTS. OTHER TRIAC APPLICATIONS VARY WITH INDIVIDUAL MACHINES AND FEATURES.			

A Triac switching function may be checked by connecting the Triac tab to ground which energizes the respective load. They are replaced by removing the I/O Board from the cabinet, turning the board over and unsoldering the connections. Place the new Triac in position and resolder.

DESCRIPTIONS OF BOARDS

BADGE BOARD (Slot I.D.):

CREDIT DISPLAY BOARD: Consists of seven LED display modules which are used for displaying credit winnings and credit totals and for displaying the number of credits gambled on each handle pull.

***DELAY RELAY BOARD** (P.59): Used only on the Series 1000, this unit consists of a 50 VDC relay which switches the 50 VAC from the transformer secondary voltage supply. Other components on the board provides the control for the relay and the assertion of a reset signal in the event of a power failure.

***DISPLAY BOARD:** (p.8) Consists of six LED display modules which are used for displaying coins paid in and out, test functions and to identify machine malfunctions.

DISPLAY CREDIT BOARD (Replay Register): Used on machines with Credit Play, it is a four digit, seven segment display board that is controlled by the M.P.U. Board.

DISPLAY DRIVER BOARD: It provides decoded signal outputs directed to the Small and Large Replay Display Board Assemblies.

***DOUBLE PROGRESSIVE DISPLAY UNIT:** It is a peripheral device that displays seven or eight digit numbers, that represent the progressive jackpot values. The unit consists of two printed circuit boards the **PROGRESSIVE DISPLAY BOARD** (p. 9) and the **DISPLAY DRIVER BOARD** (Progressive Display Controller Board).

***HOPPER CONTROL BOARDS:** (See page 47)

***I.O. BOARD** (INPUT/OUTPUT: (See pages 52-54)

***I.O. BUFFER:** This board is used to amplify and isolate address buss, data buss and control lines going into the sound insert display interface board.

***MICROPROCESSOR** (M.P.U.): See pages 56 & 57).

***POWER SUPPLY BOARD:** (See page 58)

***REEL READER CONTROL BOARD:** (See page 46)

***SLOT I.D. BOARD:** Located on the I.O. Board,

SLOT MONITOR BOARD (RX/TX): This board serves as an interface between the I/O Board and an external transmit and receive element (ie, slot monitor system). The signal transferred over these lines are typically slot machine meter status (ie, coin in , coin out, etc.).

SOUND BOARD: (See page 56)

SMART BOARD: Interfaces with the Badge Board, sends a signal to the Interrupt Decoder on the M.P.U. and is utilized in conjunction with an Electric Door lock.

* Denotes boards that can be checked on the Slot Stimulator Test Station page 59.

GAME TRANSFORMERS (Input / Output Voltages)

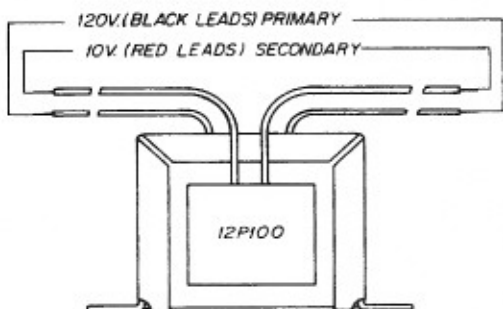

DOUBLE PROGRESSIVE BOARD POWER

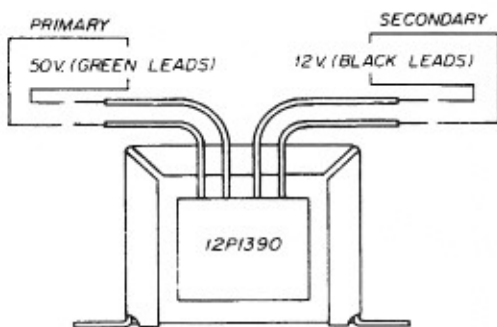

SOUND BOARD POWER

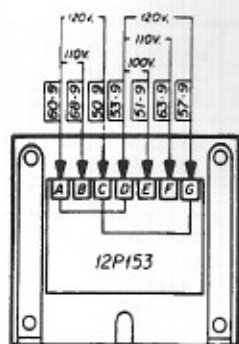

PRIMARY

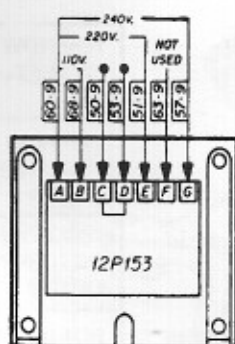

PRIMARY

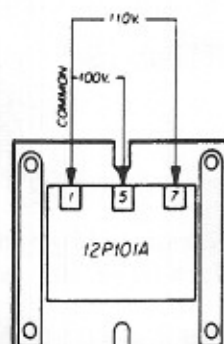

PRIMARY

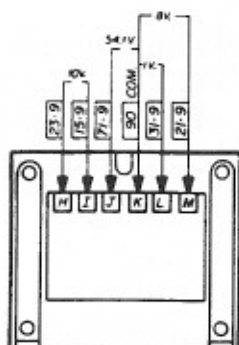

SECONDARY TRANSFORMER WIRING
120V, 50/60Hz.

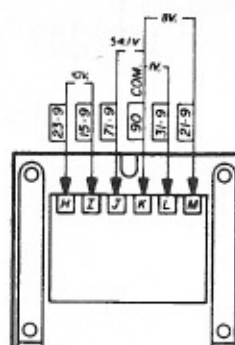

SECONDARY TRANSFORMER WIRING
220/240V, 50/60Hz.

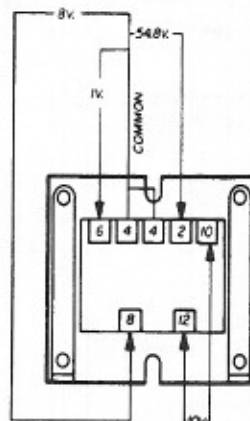

SECONDARY

MAIN GAME POWER

INPUT / OUTPUT VOLTAGE SCHEMATIC

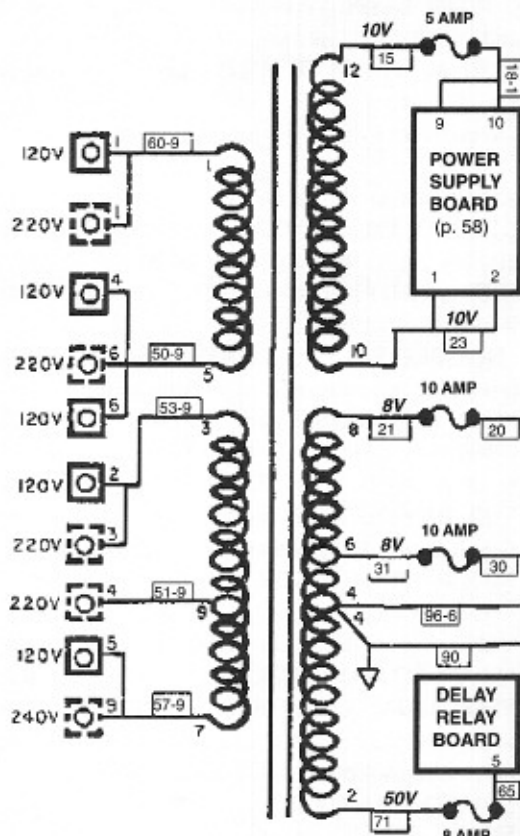
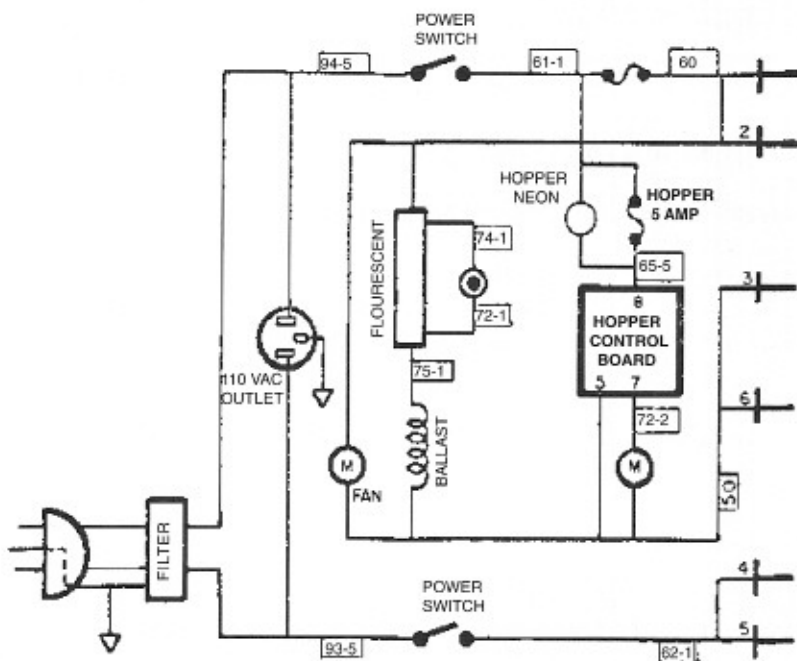

WIRE COLORS USED FOR BASIC VOLTAGES

- | | |
|--------------------------|--|
| 110 Volts: Wires 50 & 60 | Flourescent Lights & Hopper Motor |
| 50 Volts: Wires 70 & 90 | Relays, Coils, Buzzer, Chime, etc. |
| 9.5 Volts: Wires 30 & 20 | General Illumination |
| 7.5 Volts: Wires 20 & 90 | Bell, Coin Played Lights, Winner Paid Lights, etc. |

Note: The Delay Relay Board was only used on the Series 1000 On the Series 2000 it was replaced by an encapsulated CR Relay.

TROUBLE SHOOTING



MACHINE IS DEAD and the Fluorescent lights do not lite:

1. Check to see if there is 110 volts at wall receptacle.
2. Plug a 110 volt item into the 110V Outlet inside the machine to verify that the line cord is good.
3. Check to see if the 5 amp line fuse (no. 6) is not blown.

MACHINE IS DEAD and the fluorescent lights are lit and the LED Display is not lit:

1. Check the fuses (nos. 1-5). Play the machine a few times after replacing the fuse and if it blows again locate the problem.
2. Unplug each peripheral component separately (Reel Mech, Hopper, Sound Board, Top Sign Unit, and Progressive Unit). **TURN OFF POWER SWITCH** while unplugging each component. If the problem is in any of these units the LED lights will come on.
3. Check the Power Supply Unit: 1. Check the three voltages on the Test Clips (page 58).
If the "J1" Wafer is blackened chances are that the Power Supply Board is at fault. This may be caused by a faulty part or a bad connection. To correct the latter, pull out the corresponding pin, clean and replace.

MACHINE IS MALFUNCTIONING and the LED Display is lit: Refer to Malfunction Codes on pages 20-23 & 26.

REPLACING FUSES: Turn off the main **POWER SWITCH** before inspecting fuses. Replace the fuse and test the machine. If the fuse blows again locate the problem.

HOPPER FUSE 5 Amp 3 AG Hopper Fuse is located on the front frame of the Hopper. A red lamp, located above the fuse, lights when the fuse is burned out.

SWAPPING BOARDS: If a second machine is available a problem may be located by swapping boards, The M.P.U. Boards on a Series 1000 and Series 2000 can not be interchanged.

REELS KEEP SPINNING. Check the Kick and Arm Switches (see page 33).

NOT READING REELS: Check the Reel Reader Assembly for a light reading malfunction. The early models used a 50 volt lamp (#860) and on the later ones utilized an infra-red LED. (See page 46). To adjust the Position Readers refer to page 32. To check to see if the Position Reader is aligned with the holes on Index Discs see page 13.

CHECKING POWER ON BOARDS: Check the individual voltages on the Test Clips (TP1, etc.) for each board. I/O Board, page 54 (5 volts); M.P.U. Board, page 56 (5 volts); Sound Board, page 55; and Power Supply Board page 58.

CHECKING P.C. BOARD FLAT CABLES. Turn off **POWER SWITCH** remove carefully and test corresponding pins on each end of the cable for continuity with a tester.

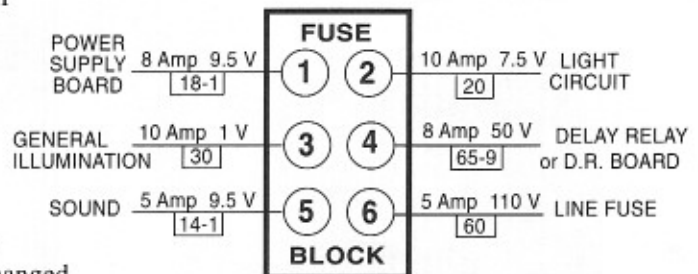

A typical fuse configuration

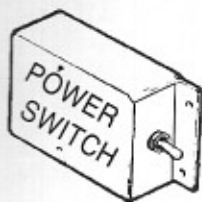

ALWAYS turn off the main Power Switch and unplug the line cord before removing or installing any assembly, connector or component. Before handling Integrated Circuits be sure to dissipate any static charges which may have built up in the body. Some of the Integrated Circuits may be damaged by direct contact with static electricity.



A PARTIAL LIST OF DEALERS THAT SELL PARTS

Bally Gaming, Inc., 1-(800) HOT SLOT, 6601 So. Bermuda Rd, Las Vegas, NV 89119 Bally Gaming, Inc., Northern Nevada, (702) 685- 7737, 1400 Greg St., Sparks, NV 89431

Bally Gaming, Inc. will only sell and repair parts with customers that are a Nevada resident and have a valid Nevada driver's license. Non-residents may obtain parts and repairs through independent dealers in legal states.

Wico Corporation, 1-(800) FOR WICO (some electronic & mechanism parts) 6400 West Gross Point Rd., Niles, IL 60714. Wico offers a catalog that pictures E machine parts and lists their cross reference numbers.

For a local parts dealer in "legal states" refer to the "Slot Machines — Antique" listing in the phone book's yellow page index. These dealers names and addresses are also available in the many trade publications.

Dealer Repairs

For a local repair technician in "legal states" refer to the "Slot Machines — Antique" listing in the phone book's yellow page index or a trade publication. For major board repair check with your local dealer. If you feel you need extensive board repair, it may be advisable to locate a technician with a Slot Simulator Test Station (page 59).