

SERIES E

Manual FO-650-14

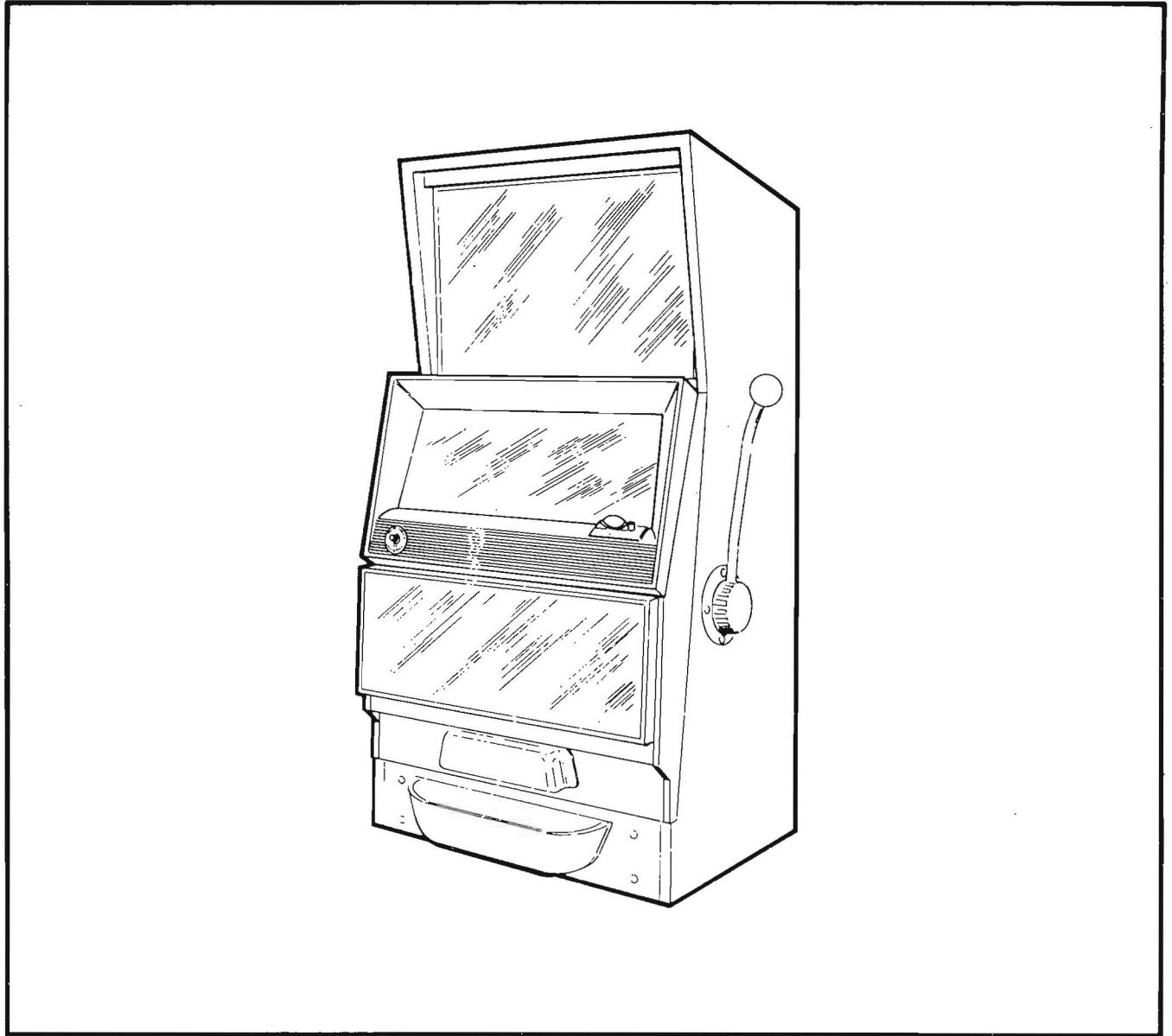

SLOT MACHINE SCHEMATICS MANUAL

Bally[®]

MANUFACTURING CORPORATION
GAMING DIVISION

90 O'Leary Drive, Bensenville, Illinois 60106, U.S.A.
Telephone: (312) 860-7777 Cables: Balfan Telex: 210277

© 1984 Bally Mfg. Corp.
All Rights Reserved

INTRODUCTION

This manual consolidates the electronic slot game schematics (series W-1046) into one comprehensive format. The diagrams contained in this manual are representative of all electronic slot machines available. The overall electrical diagram is organized into readily identified categories for ease of troubleshooting.

The schematics must be read and interpreted on a game per game basis, using Form #FO-652 (Specific Model Information) to define game personality, options, and properly identify the circuits concerned.

For example, on Page #4, J1-Pin 19 has several wires shown. Use only the functional information for that position which applies to the game involved. Other wires at that position can be ignored. This principle also applies to various optional circuitry and cabling illustrated throughout the manual.

TABLE OF CONTENTS

	Page
GAME TRANSFORMERS (INPUT/OUT VOLTAGE)	1
GAME POWER DISTRIBUTION	2
P.C. BOARD POWER DISTRIBUTION	3
I/O BOARD J-1	4
I/O BOARD J-2, J-3	5
P.C. BOARD INTERCONNECTIONS	6

RMERS
GES)

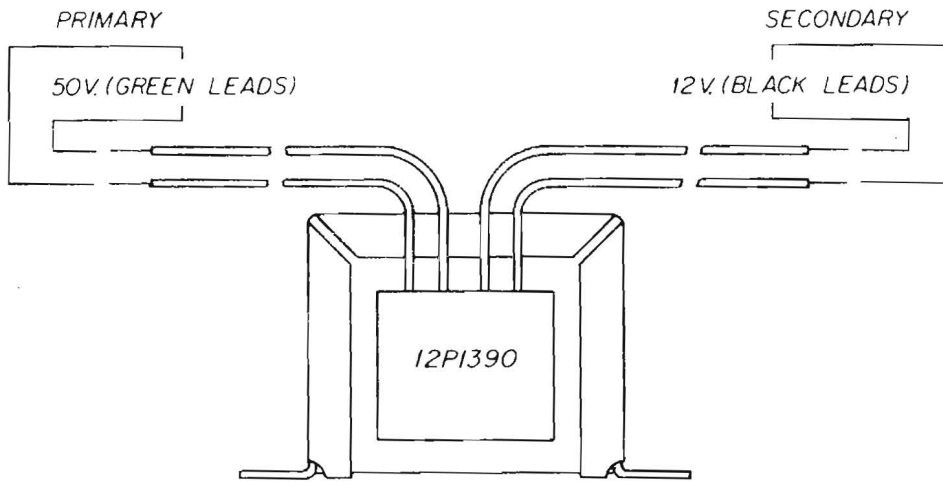

E-122-149a
TRANSFORMER

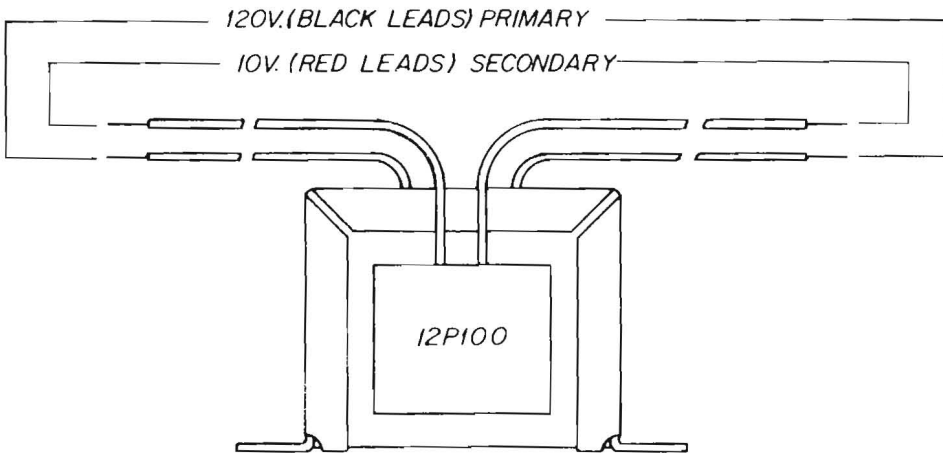

E-122-157a
TRANSFORMER

(APAN)
XMER)
ER (SEC. XMER)

GAME TRANSFO

(INPUT/OUTPUT VOLT

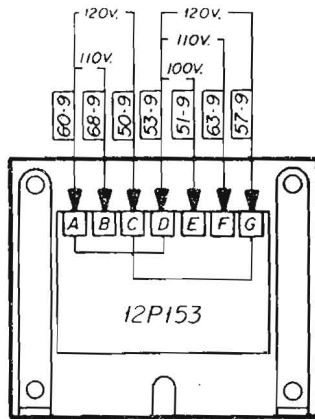

PRIMARY

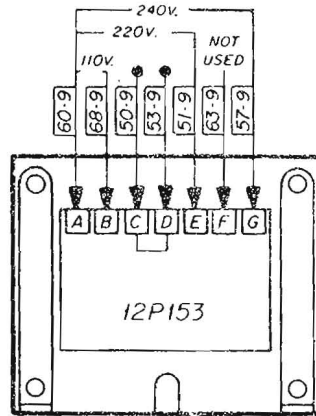

PRIMARY

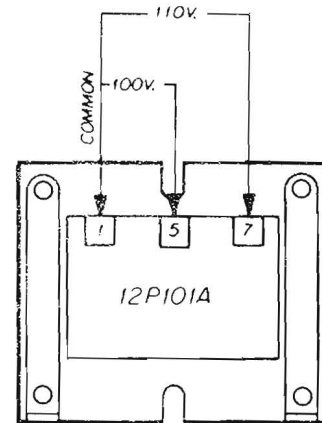

PRIMARY

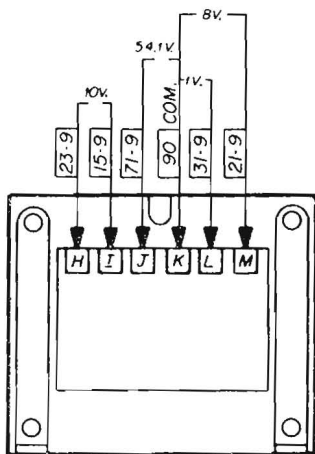

SECONDARY
TRANSFORMER WIRING
120V. 50/60Hz.

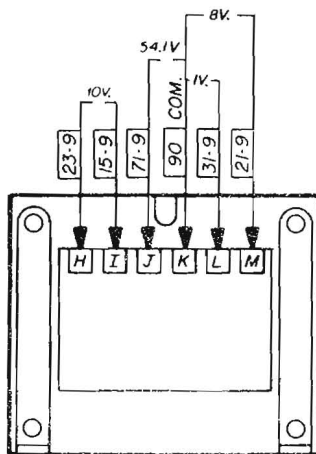

SECONDARY
TRANSFORMER WIRING
220/240V. 50/60Hz.

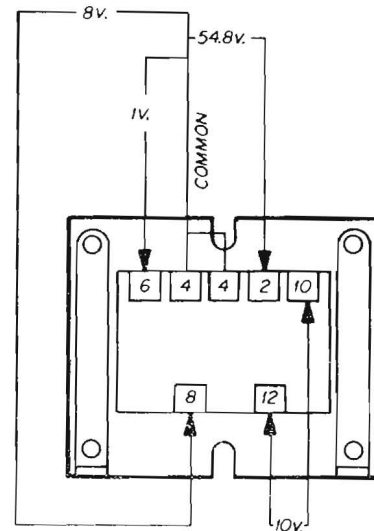

SECONDARY
E-122-138 a
TRANSFORMER

E-122-151 &
TRANSFORMER

TRANSFORMER	USE
E-122-151	GAME POWER (MAIN XMER)
E-122-138	GAME POWER (MAIN XMER) (J)
E-122-157	SOUND BOARD POWER (SEC)
E-122-149	DOUBLE PROG. BOARD POW

120 V.A.C. & MAIN TRANSFORMER POWER DIST

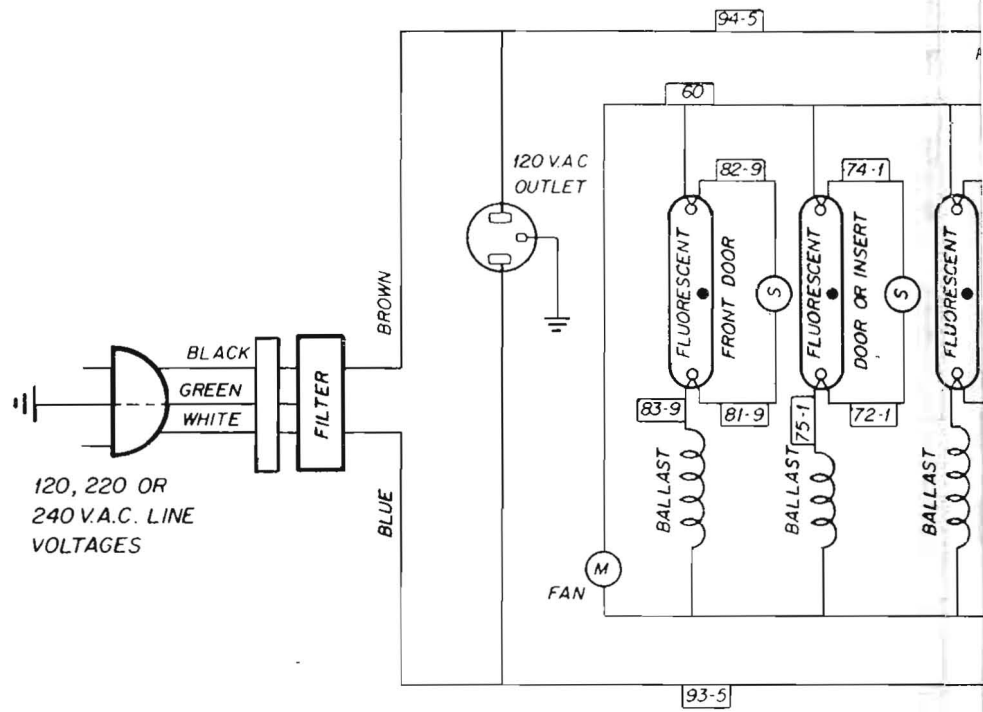

110 V.A.C. & MAIN TRANSFORMER POWER DISTRIBUTION

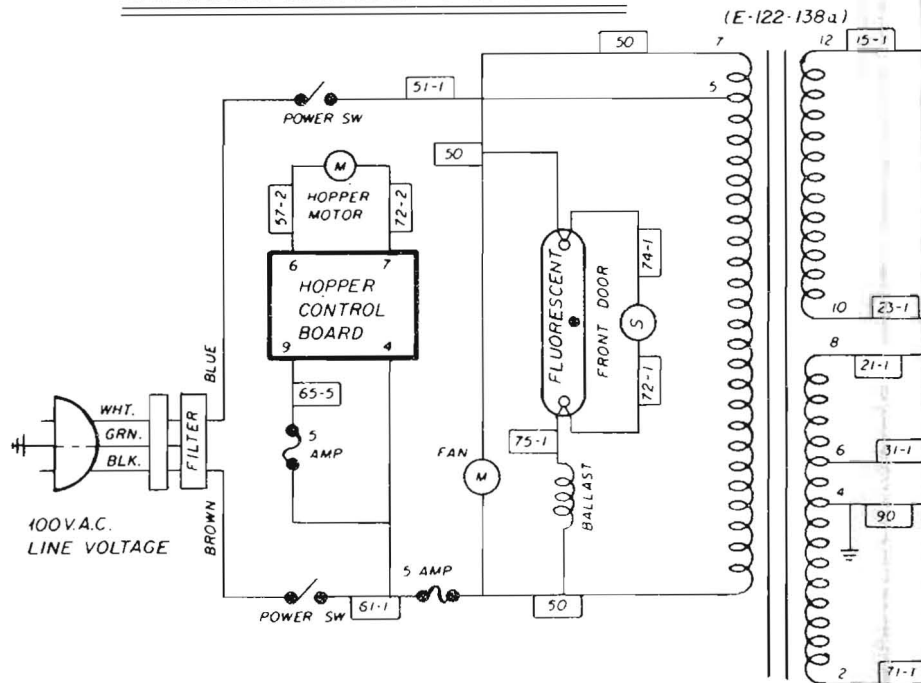

GAME POWER DISTRIBUTION

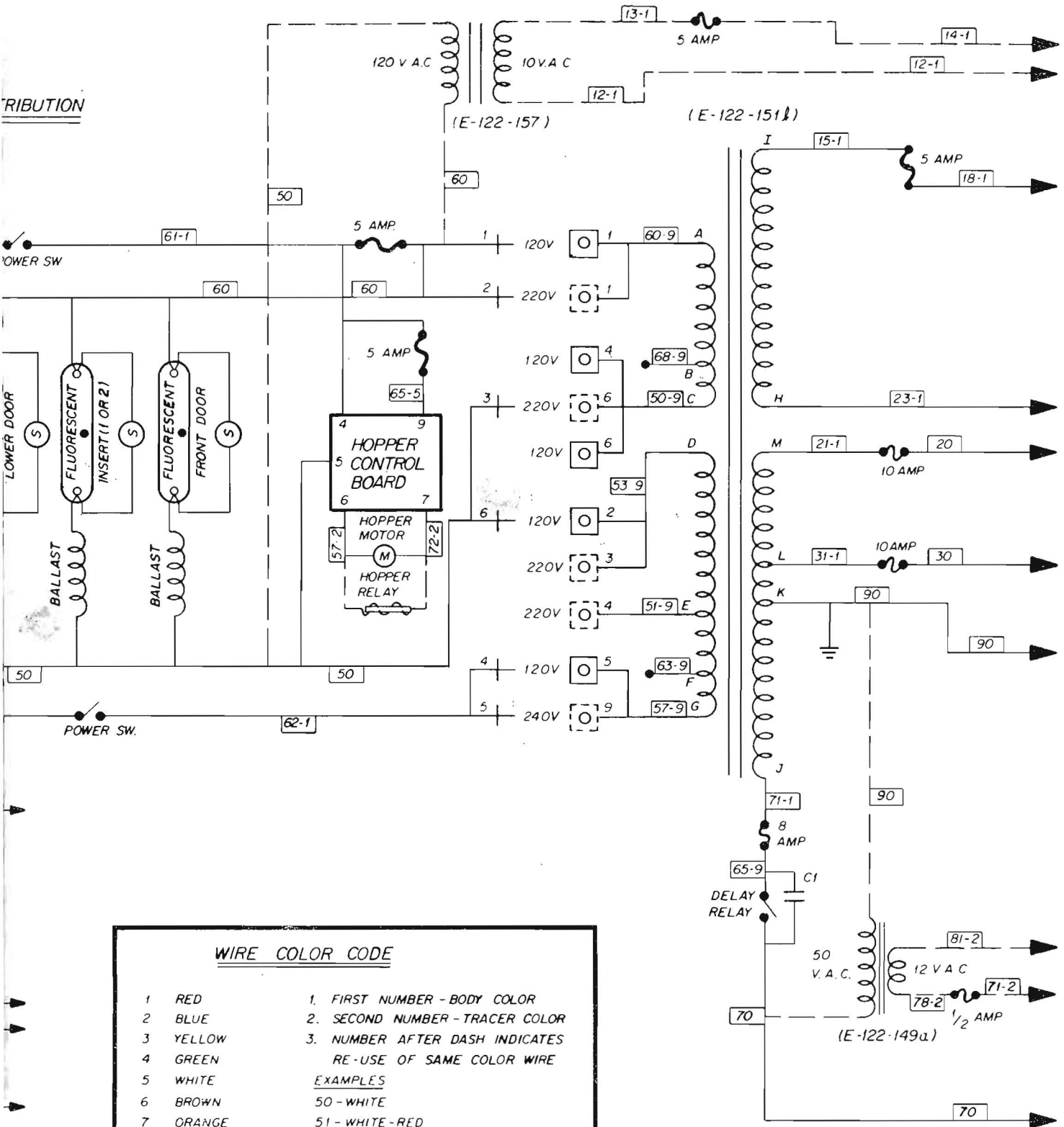

WIRE COLOR CODE

- | | |
|-------------|---------------------------------|
| 1 RED | 1. FIRST NUMBER - BODY COLOR |
| 2 BLUE | 2. SECOND NUMBER - TRACER COLOR |
| 3 YELLOW | 3. NUMBER AFTER DASH INDICATES |
| 4 GREEN | RE-USE OF SAME COLOR WIRE |
| 5 WHITE | <u>EXAMPLES</u> |
| 6 BROWN | 50 - WHITE |
| 7 ORANGE | 51 - WHITE - RED |
| 8 BLACK | 51-1 WHITE - RED (USED AGAIN) |
| 9 GRAY | 51-2 WHITE - RED (USED AGAIN) |
| 0 NO-TRACER | 27 - BLUE - ORANGE |
| J JUMPER | 27-1 BLUE - ORANGE (USED AGAIN) |

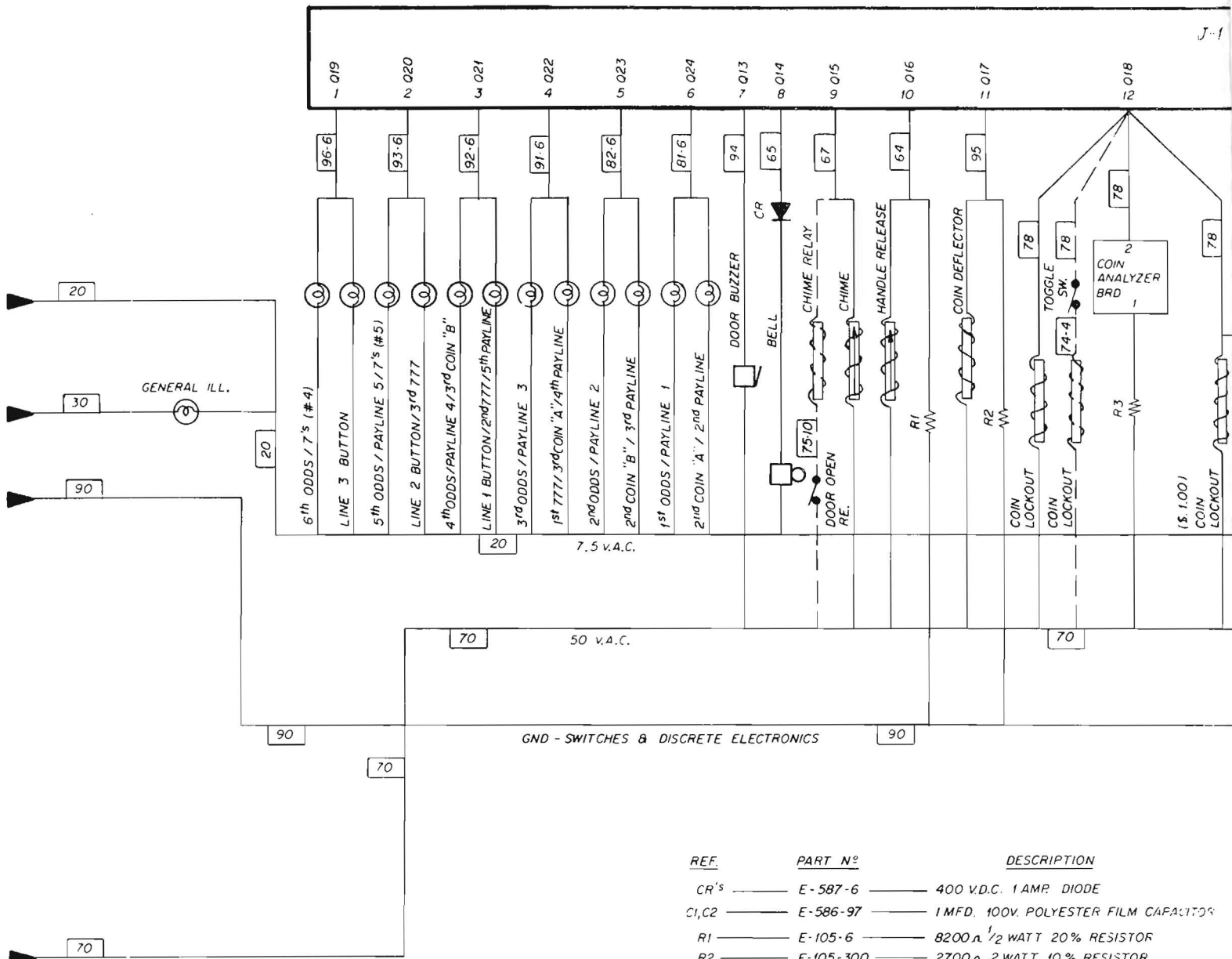

REF.	PART N°	DESCRIPTION
CR ⁵	E-587-6	400 V.D.C. 1 AMP. DIODE
C1, C2	E-586-97	1 MFD. 100V. POLYESTER FILM CAPACITORS
R1	E-105-6	8200Ω 1/2 WATT 20% RESISTOR
R2	E-105-300	2700Ω 2 WATT 10% RESISTOR
R3		620Ω RESISTOR
R4	E-104-101	470Ω 2 WATT 5% RESISTOR
K1	E-146-806	6 V.D.C. CR. RELAY
V1	E-713-3	GE N° VICO2A3 VARISTOR

J-1

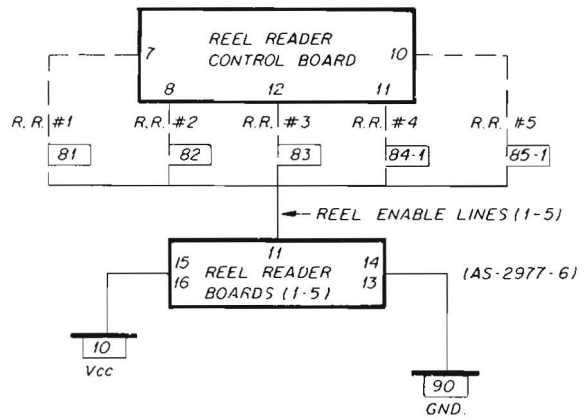
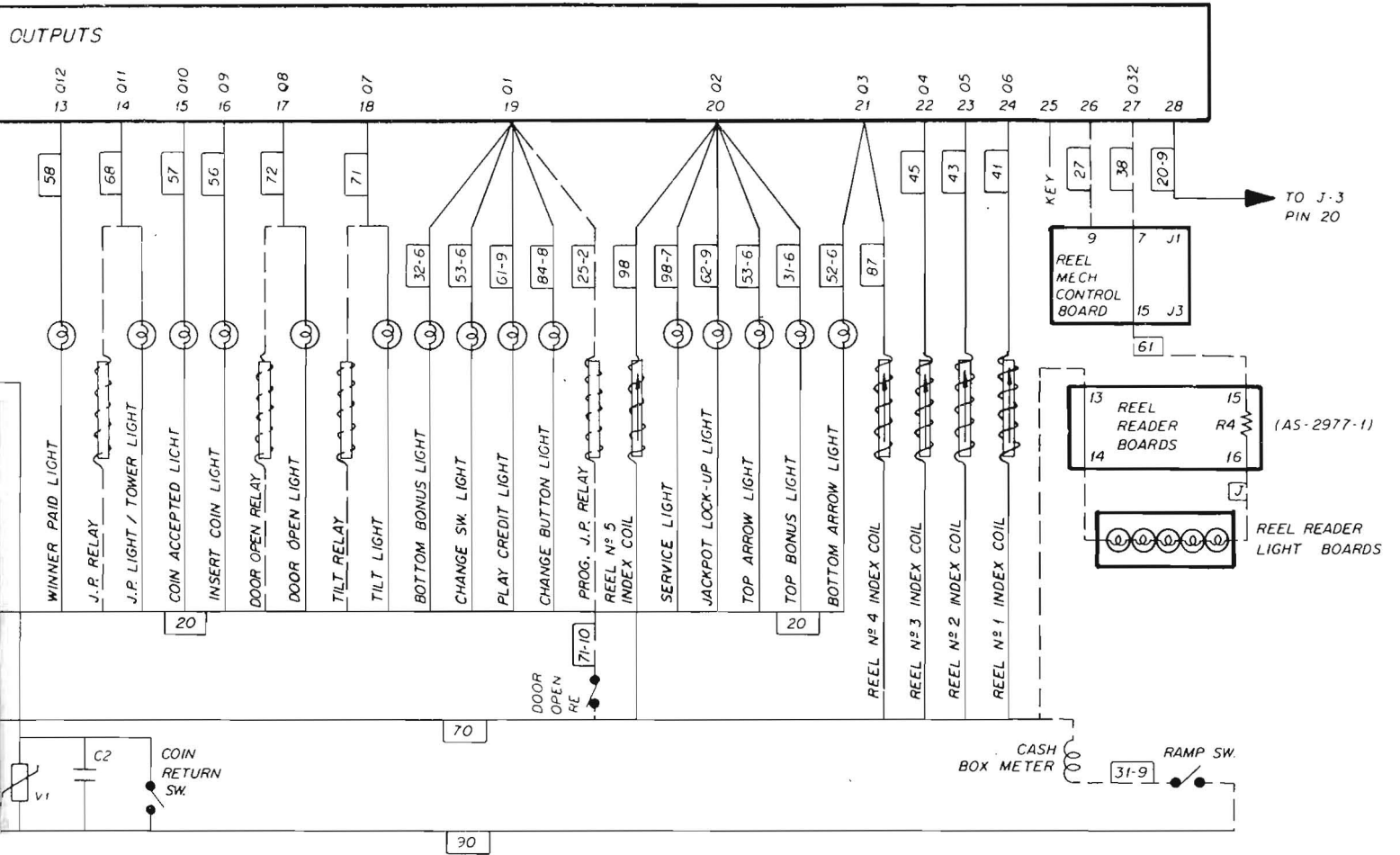

P. C. BOARD POWER DISTRIBUTION

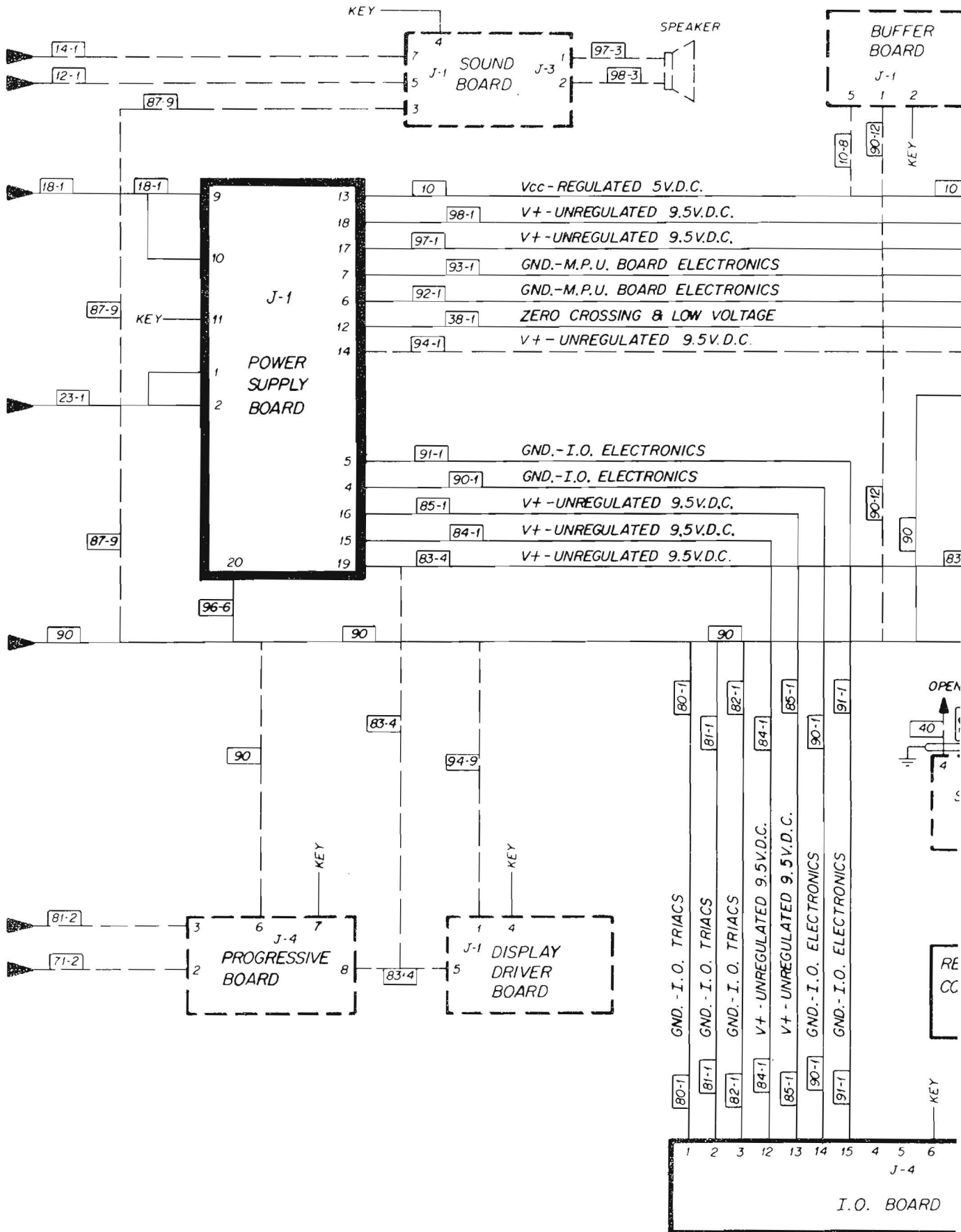

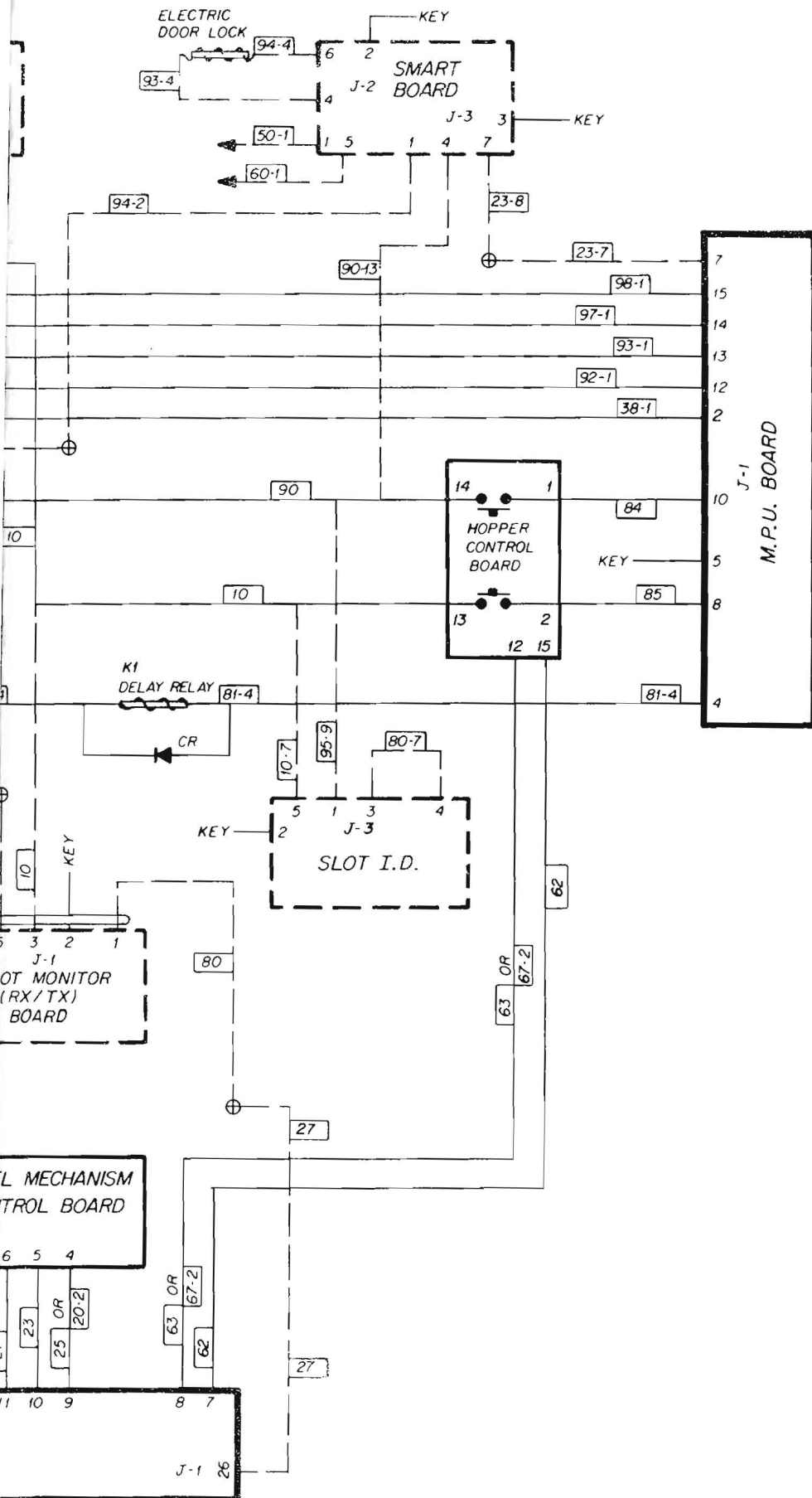

P.C. BOARD FLAT
CABLE INTER

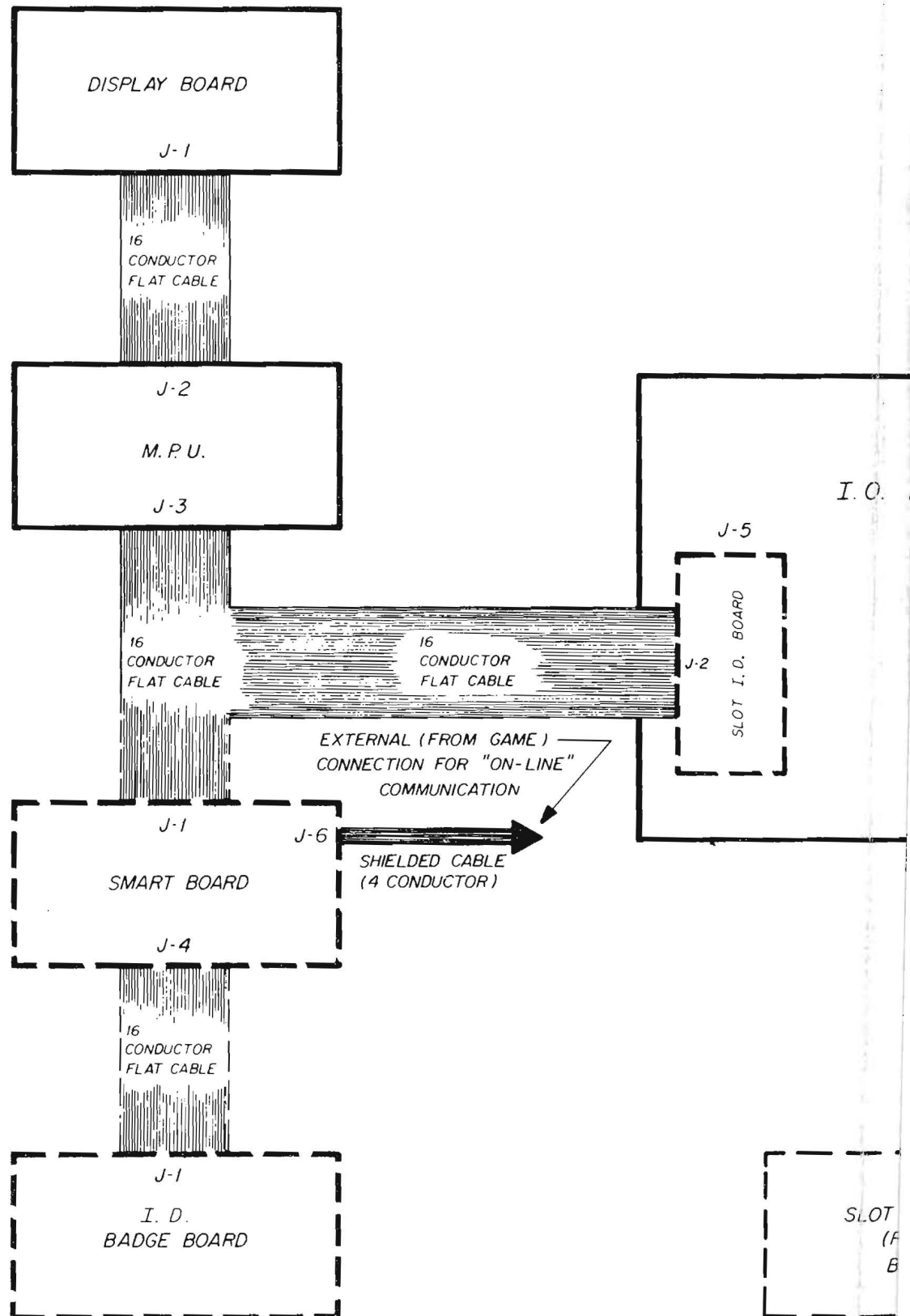

AND SHIELDED CONNECTIONS

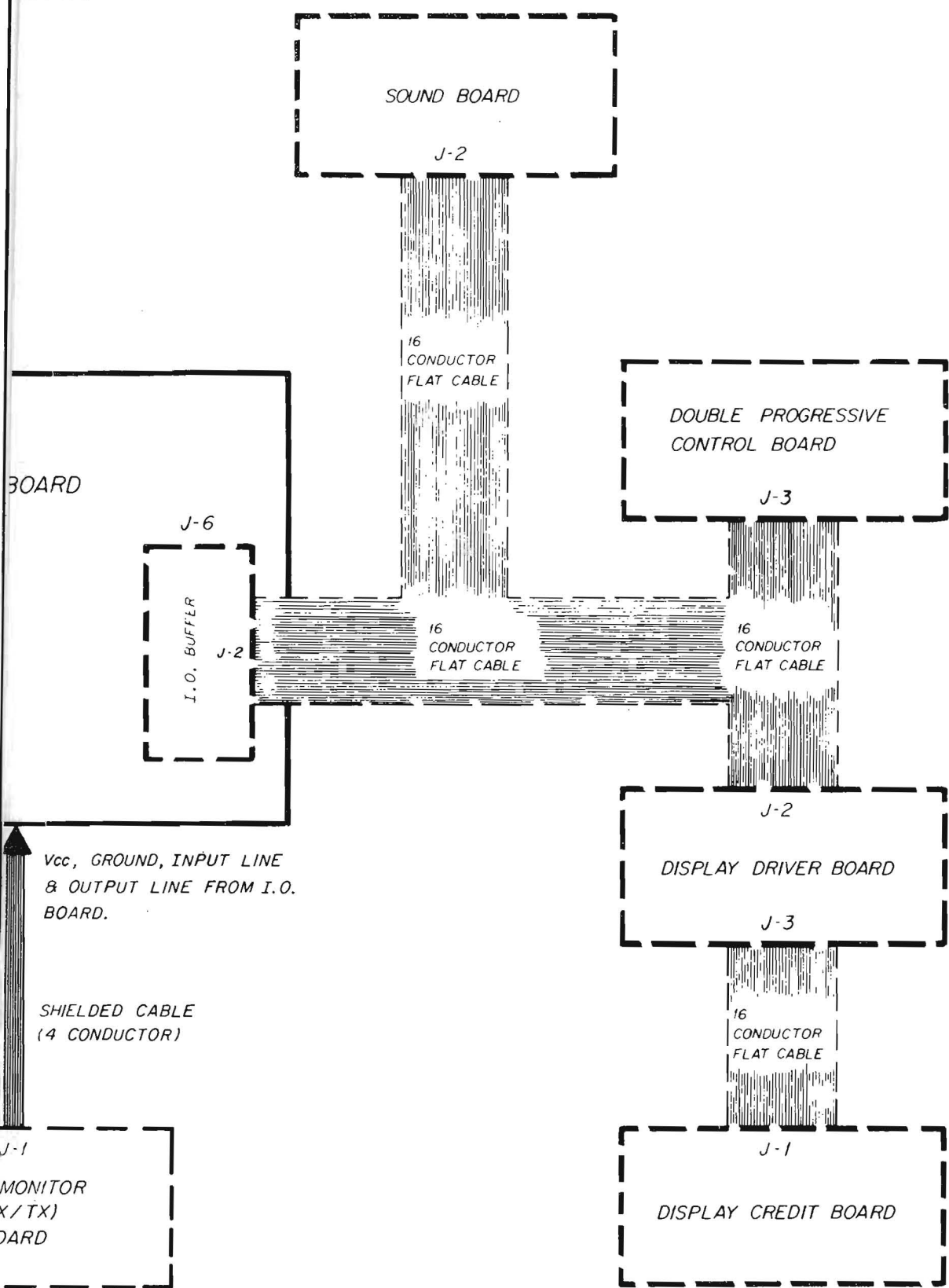

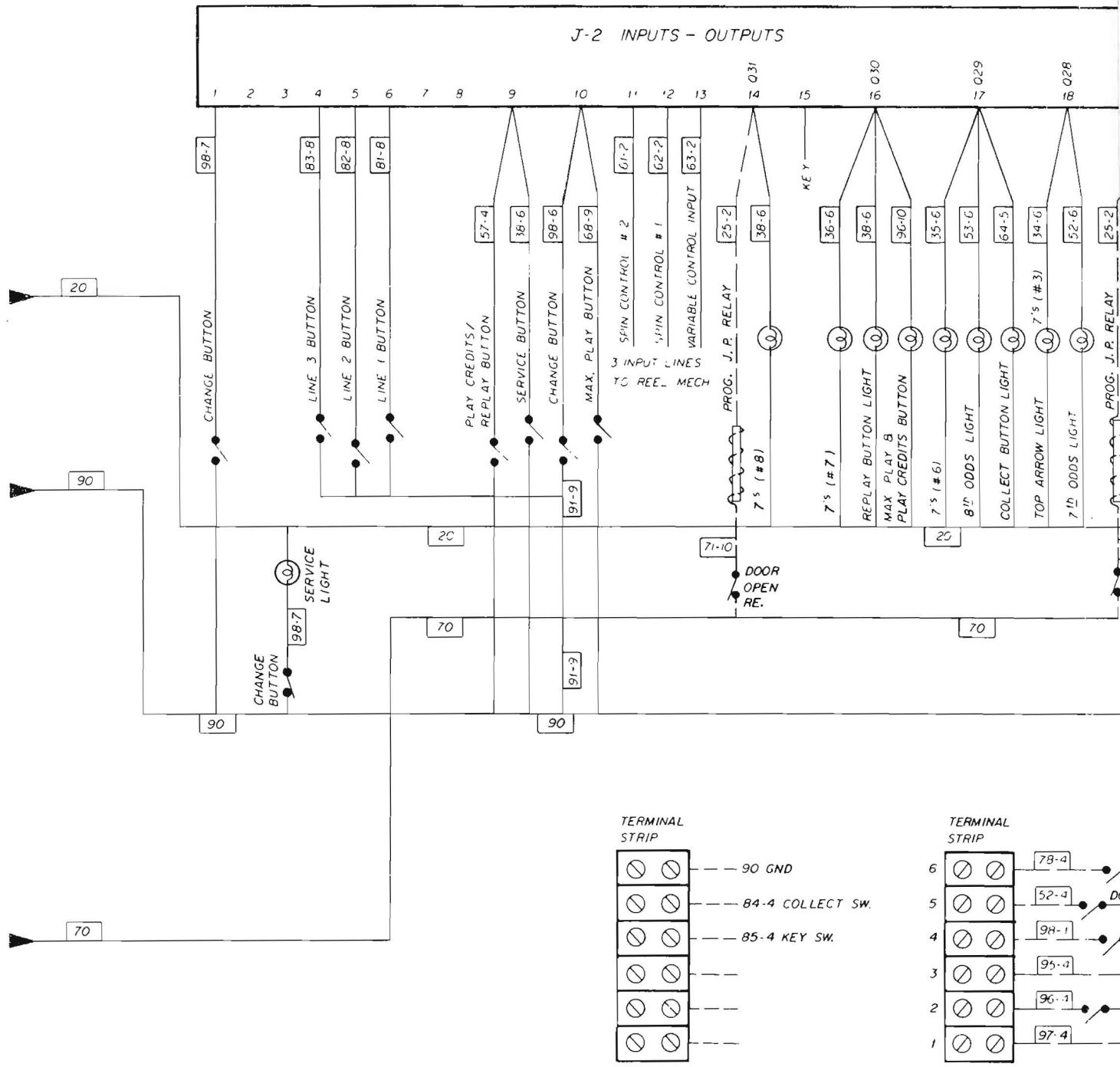

TERMINAL STRIP

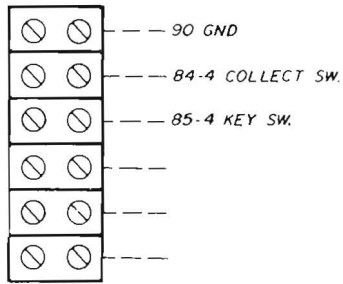

TERMINAL STRIP

